



TIMBERWOLF[®]
Lead the pack

TW 18/100G WOOD CHIPPER
UK INSTRUCTION MANUAL
(ORIGINAL INSTRUCTIONS)



timberwolf-uk.com

© Copyright Timberwolf Ltd 2018

The content of this publication may not be copied, reproduced, republished, posted, broadcast, transmitted or used in any way in any medium without the written permission of Timberwolf Ltd.

| <i>Section</i> | <i>Page No.</i> |
|--|-----------------|
| INTRODUCTION | 2 |
| PARTS LOCATOR | 3 |
| SAFE WORKING | 5 |
| Operator's Personal Protective Equipment (PPE) | 5 |
| Basic Woodchipping Safety | 5 |
| General Safety Matters | 5 |
| Noise Test | 6 |
| Safe Transportation | 7 |
| Hitching onto the Tow Ball | 7 |
| Unhitching the Chipper | 7 |
| STORAGE | 8 |
| Storing the Chipper | 8 |
| OPERATING INSTRUCTIONS | 9 |
| Recommissioning after storage | 9 |
| Delivery | 9 |
| Engine Controls | 9 |
| Starting the Engine | 9 |
| Stopping the Engine | 9 |
| Emergency Stopping | 9 |
| Daily Checks Before Starting | 10 |
| Discharge Controls | 10 |
| Starting to Chip | 10 |
| Chipping | 10 |
| Blockages | 11 |
| Blade Wear | 11 |
| Fuel Level Indicator | 11 |
| Refuelling | 11 |
| Troubleshooting | 12 |
| SERVICE INSTRUCTIONS | 13 |
| Service Schedule | 13 |
| Safe Maintenance | 14 |
| Safe Lifting of the Chipper | 14 |
| Spares | 14 |
| Battery Removal and Maintenance | 14 |
| Check Fittings | 14 |
| Hazardous Materials and End of Machine Life | 15 |
| Battery Safety Information | 16 |
| Change Blades | 17 |
| Tension Drive Belts | 17 |
| Grease the Discharge Flange | 17 |
| Engine Servicing | 17 |
| WARRANTY STATEMENT | 18 |
| DECLARATION OF CONFORMITY | 19 |
| IDENTIFICATION PLATE | 20 |
| DECALS | 21 |
| CIRCUIT DIAGRAM | 23 |
| V-BELT TENSIONING TABLE | 24 |
| WARRANTY SERVICE RECORD CHECK | 25 |
| SERVICE RECORD | 26 |
| PARTS LISTS | 27 |

Thank you for choosing Timberwolf. Timberwolf chippers are designed to give safe and dependable service if operated according to the instructions.

IMPORTANT HEALTH AND SAFETY INFORMATION

Before using your new chipper, please take time to read this manual. Failure to do so could result in:

- personal injury
- equipment damage
- damage to property
- 3rd party injuries

This manual covers the operation and maintenance of the Timberwolf TW 18/100G. All information in this manual is based on the latest product information available at the time of purchase.

All the information you need to operate the machine safely and effectively is contained within pages 3 to 11. Ensure that all operators are **properly trained** for operating this machine, especially in **safe working practices**.

Timberwolf's policy of regularly reviewing and improving their products may involve major or minor changes to the chippers or their accessories. Timberwolf reserves the right to make changes at any time without notice and without incurring any obligation.

Due to improvements in design and performance during production there may be, in some cases, minor discrepancies between the actual chipper and the text in this manual.

The manual should be considered an important part of the machine and should remain with it if the machine is resold.



CAUTION or WARNING

BE AWARE OF THIS SYMBOL AND WHERE SHOWN, CAREFULLY FOLLOW THE INSTRUCTIONS.

THIS SYMBOL INDICATES IMPORTANT SAFETY MESSAGES IN THIS MANUAL. WHEN YOU SEE THIS SYMBOL, BE ALERT TO THE POSSIBILITY OF INJURY TO YOURSELF OR OTHERS AND CAREFULLY READ THE MESSAGE THAT FOLLOWS.

ALWAYS FOLLOW SAFE OPERATING AND MAINTENANCE PRACTICES

PURPOSE

The Timberwolf TW 18/100G is designed to chip solid wood material up to 100mm in diameter and capable of chipping over 1.5 tonnes of brushwood per hour.

DIMENSIONS

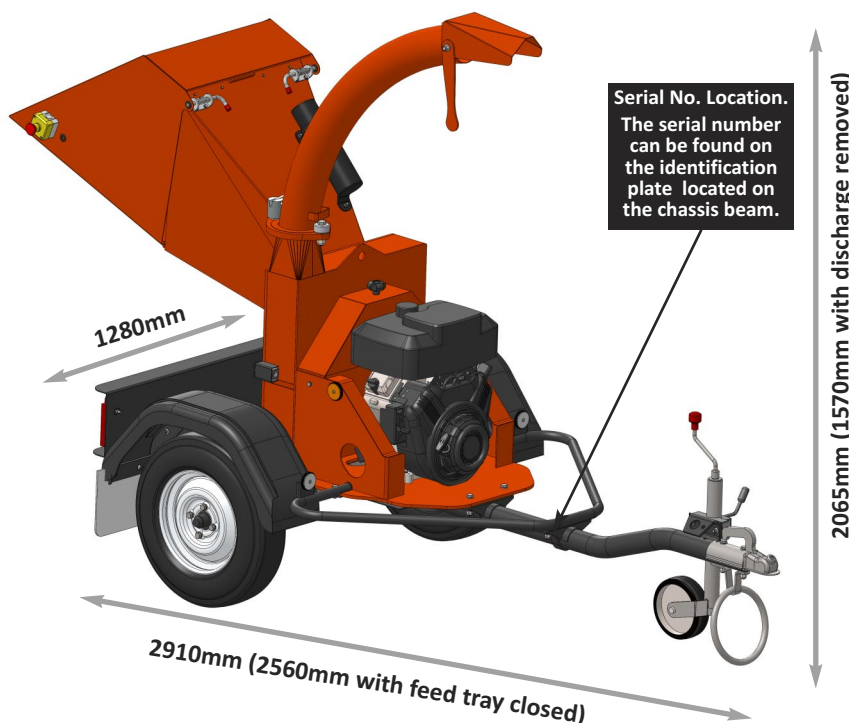

TW 18/100G SPECIFICATION

- Engine type:**
Briggs & Stratton V-Twin (electric start)
- Maximum power:**
13.4kW (18hp)
- Cooling method:**
Air cooled
- Overall weight:**
385kg
- Starting method:**
Electric
- Type of feed:**
Gravity
- Maximum diameter material:**
100mm (4")
- Fuel capacity:**
8.5 litres
- Material processing capacity:**
1.5 tonnes/hr
- Fuel type:**
Unleaded petrol

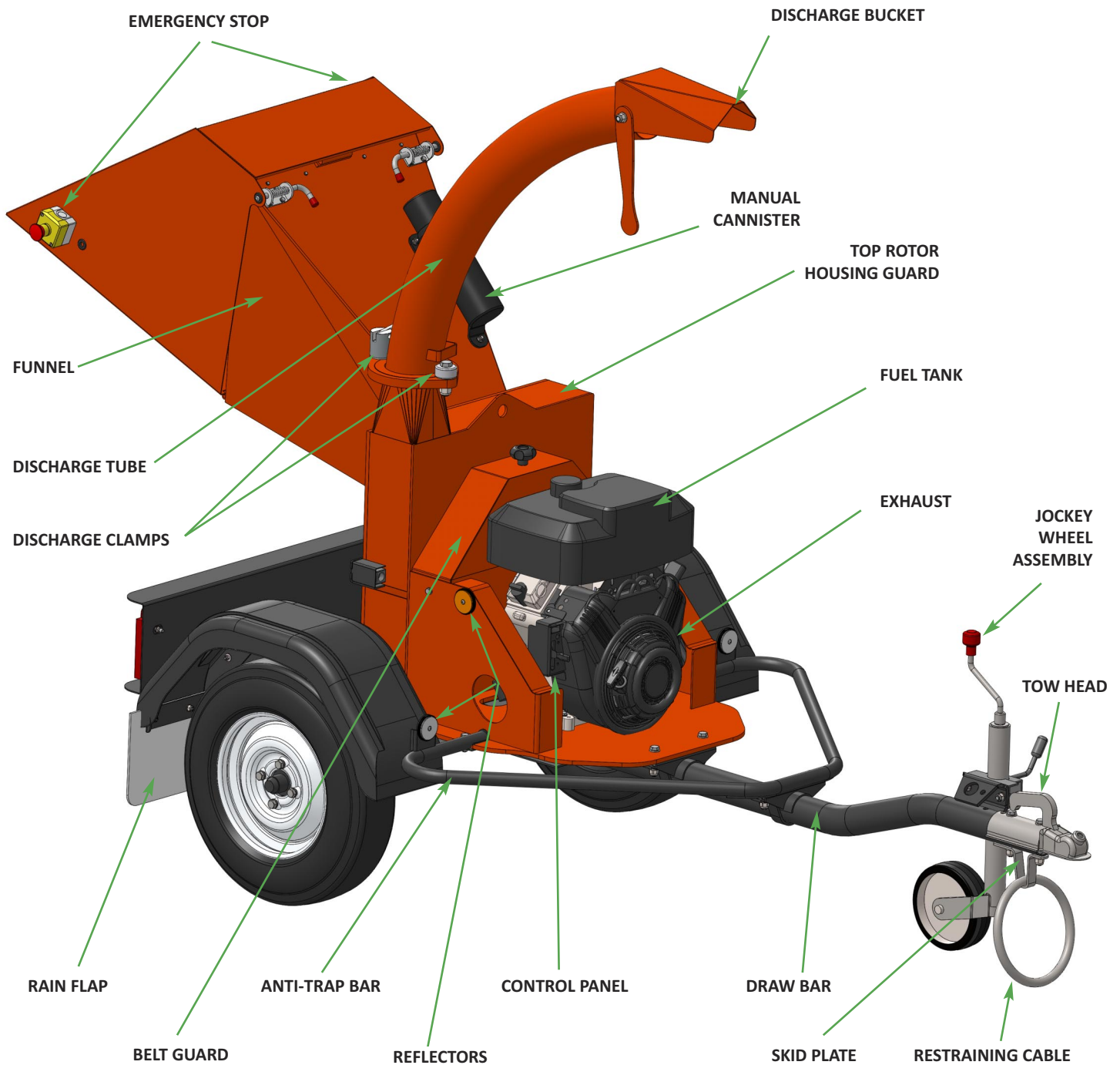

THE TW 18/100G HAS THE FOLLOWING FIXED GUARDS FOR PROTECTION OF THE OPERATOR, CHIPPER AND ENVIRONMENT:

- **Funnel:** Protects the user from injuries from moving parts and ejected material during operation.
- **Top Rotor Housing Guard:** Protects user from rotational parts e.g. cutting blades. The interlocking switch disengages the engine when the hatch is opened to stop the chipper running.
- **Belt Guard:** Protects the user from rotational parts e.g. belts and pulleys, hot surfaces and engine fluids. Protects machine from ingress of environmental debris.

Guards may be removed for maintenance only, as described in the Service Instruction pages of this manual. **Ensure guards remain in place throughout operation.**

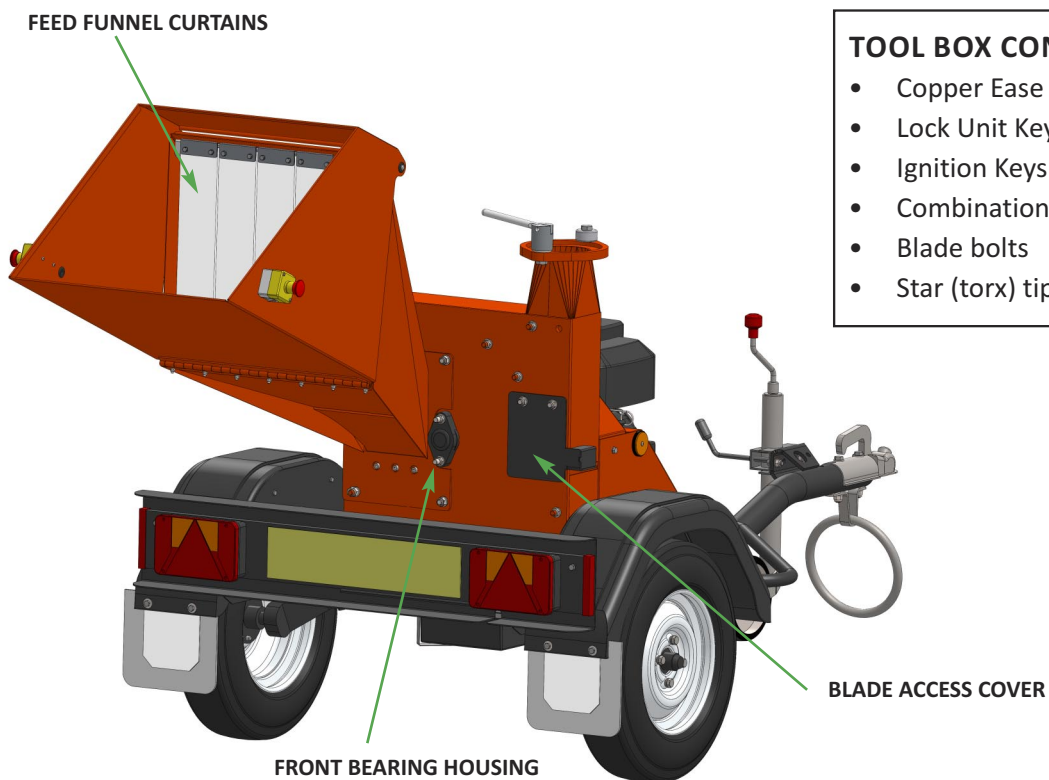
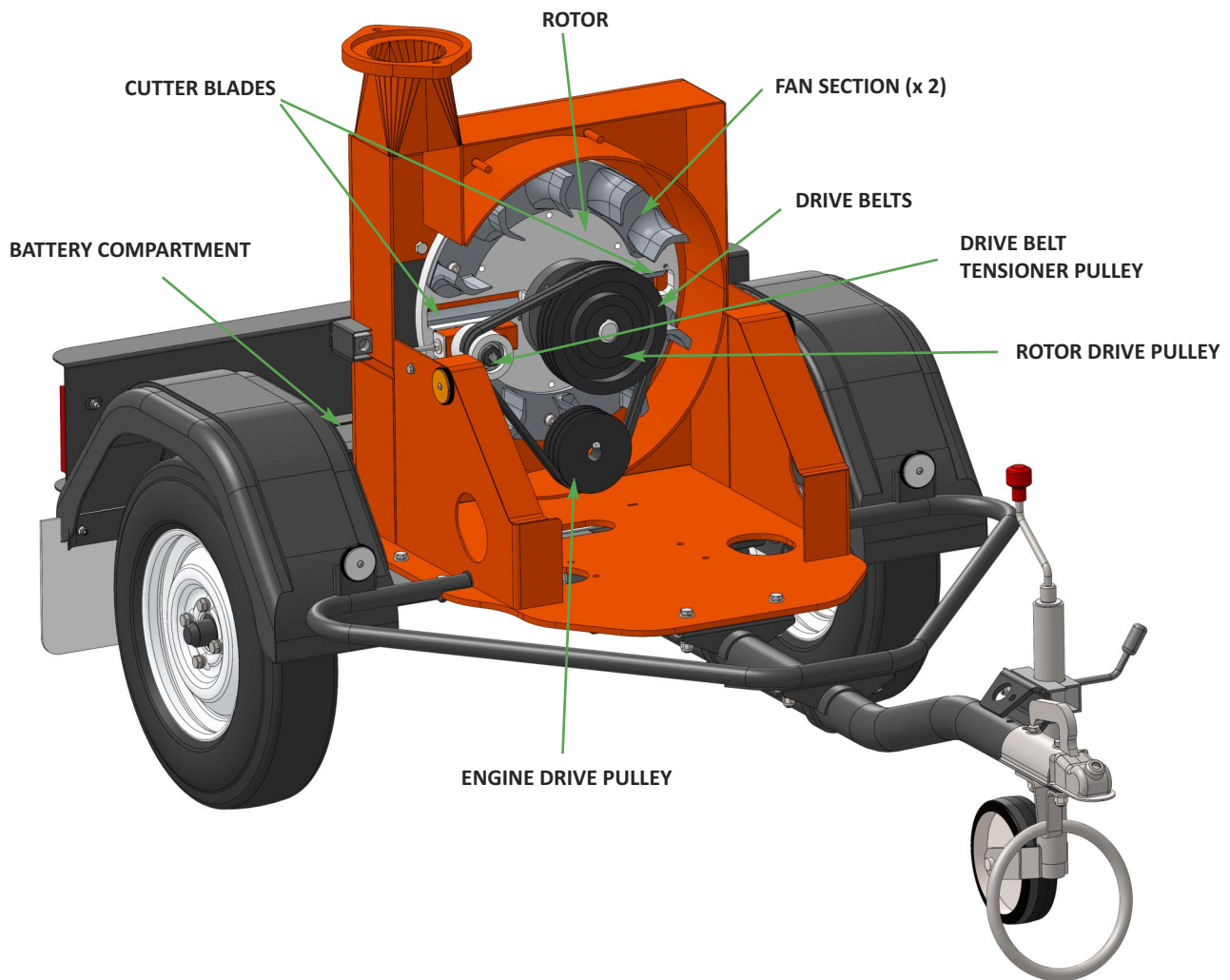

TOOL BOX CONTENTS:

- Copper Ease
- Lock Unit Keys x 2
- Ignition Keys x 2
- Combination Spanner (17mm/19mm)
- Blade bolts
- Star (torx) tip and driver

OPERATOR'S PERSONAL PROTECTIVE EQUIPMENT (PPE)

- Chainsaw safety helmet (EN 397) fitted with mesh visor (EN 1731) and ear defenders (EN 352).
- Work gloves with elasticated wrist.
- Steel toe cap safety boots (EN 345-1).
- Close fitting heavy-duty non-slag clothing. High-visibility clothing (EN 471) if risk assessment identifies the need.
- Face mask if appropriate.
- DO NOT wear rings, bracelets, watches, jewellery or any other items that could be caught in the material and draw you into the chipper.



WARNING

The chipper will feed material through on its own. To do this, it relies on sharp blades on the chipper rotor. To keep the blades sharp, only feed the machine with clean brushwood. DO NOT put muddy/dirty wood, roots, potted plants, bricks, stones or metal into the chipper.

BASIC WOODCHIPPING SAFETY

The operator should be aware of the following points:

- Maintain a safety exclusion zone around the chipper of at least 10 metres for the general public or employees without adequate protection. Use hazard tape to identify this working area and keep it clear from debris build up. Chips should be ejected away from any area the general public have access to.
- Hazardous material - Some species of trees and bushes are poisonous. The chipping action can produce vapour, spray and dust that can irritate the skin. This may lead to respiratory problems or even cause serious poisoning. Check the material to be chipped before you start. Avoid confined spaces and use a face mask if necessary.
- Be aware when the chipper is processing material that is an awkward shape. The material can move from side to side in the funnel with great force. If the material extends beyond the funnel, the brush may push you to one side causing danger. Badly twisted brush should be trimmed before being chipped to avoid thrashing in the feed funnel.
- Be aware that the chipper can eject chips out of the feed funnel with considerable force. Always wear full head and face protection.
- Always work on the side of the machine furthest from any local danger, e.g. not road side.
- Never leave the chipper unattended when running. Machines must be supervised at all times when in use.
- In the event of an accident, stop the machine, remove the key and call the emergency services immediately.

GENERAL SAFETY MATTERS

- Always stop the chipper engine before making any adjustments, refuelling or cleaning.
- Always check the rotor has stopped rotating and remove the chipper ignition key before maintenance of any kind, or whenever the machine is to be left unattended. If in doubt, look through the in-feed funnel to see if rotor is still moving.
- Always check the machine is well supported and cannot move. If working on an incline, position on solid ground, across the slope.
- Always operate the chipper with the engine set to maximum speed when chipping.
- Always check (visually) for fluid leaks. If found, resolve the leak before operating the chipper.
- Always take regular breaks. Wearing personal protective equipment for long periods can be tiring and hot.
- Always keep hands, feet and clothing out of feed opening, discharge and moving parts.
- Always use a push stick to push in short pieces. Under no circumstances should you reach into the funnel.
- Always keep the operating area clear of people, animals and children.
- Always keep the operating area clear from debris build up.
- Always keep clear of the chip discharge tube. Foreign objects may be ejected with great force.
- Always ensure protective guarding is in place before commencing work. Failure to do so may result in personal injury or loss of life.
- Always operate the chipper in a well ventilated area - exhaust fumes are dangerous.
- Ensure a fire extinguisher is available on site.
- Ensure a personal first aid kit and hand cleaning materials are available (e.g. waterless skin cleanser).

GENERAL SAFETY MATTERS

- Do not operate chipper unless available light is sufficient to see clearly.
- Do not use or attempt to start the chipper without the feed funnel, guards and discharge unit securely in place.
- Do not stand directly in front of the feed funnel when using the chipper. Stand to one side.
- Do not smoke when refuelling.
- Do not let anyone who has not received instruction operate the machine.
- Do not climb on the machine at any time.
- Do not handle material that is partially engaged in the machine.
- Do not touch any exposed wiring while the machine is running.
- Do not use the chipper inside buildings.



DO NOT ALLOW THE FOLLOWING TO ENTER THE MACHINE, AS DAMAGE IS LIKELY



CLOTH



PLASTIC



STONES



METAL



GLASS



RUBBER



BRICKS



STRING



ROOTS



BEDDING PLANTS

NOISE TEST

Machine: TW 18/100G

Notes: Tested chipping 50mm x 50mm corsican pine 1.5m in length

Noise levels above 80dB (A) will be experienced at the working position. Prolonged exposure to loud noise may cause permanent hearing loss. All persons within a 4 metre radius must also wear good quality ear protection (EN 352) at all times to prevent possible damage to hearing.

Guaranteed Sound Power: 125dB (A)

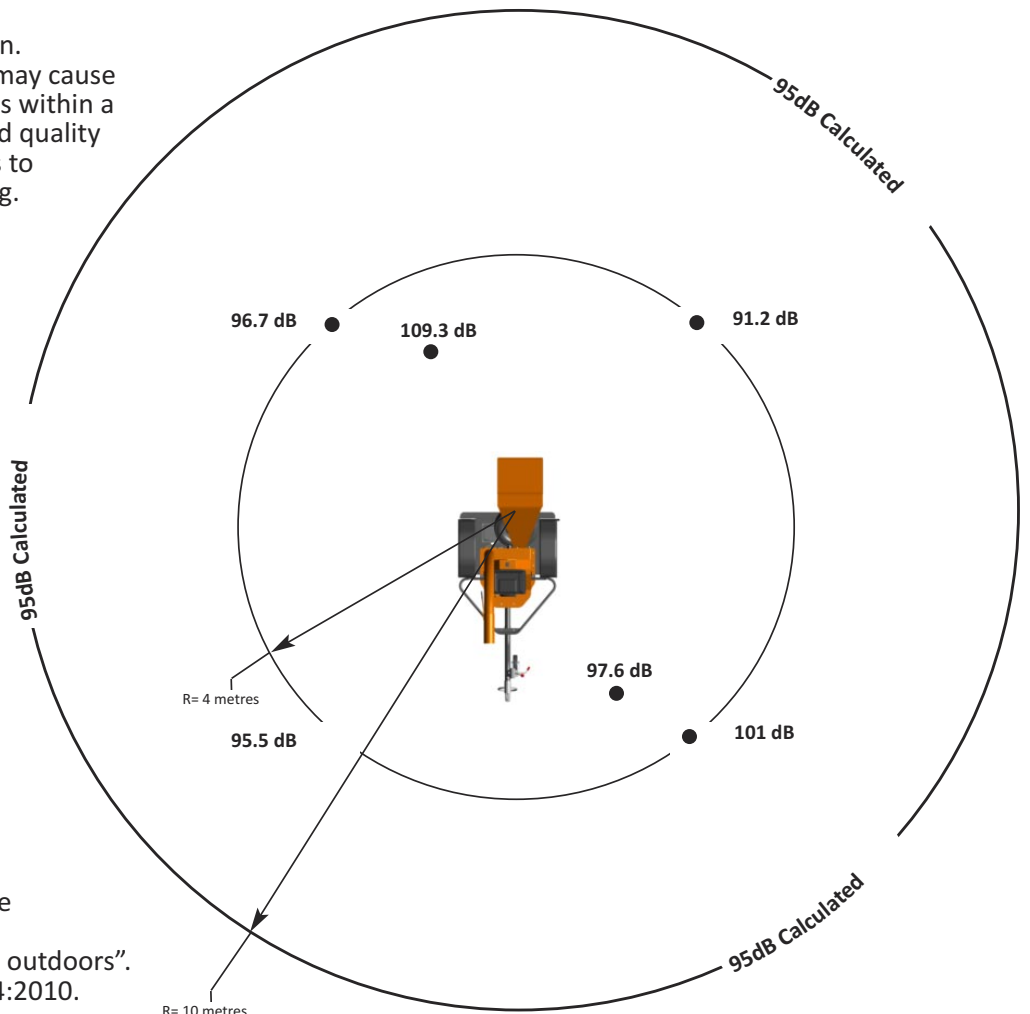

As required by Annex III of Directive 2000/14/EC "Noise Emission in the environment by equipment for use outdoors". Tested according to BS EN ISO 3744:2010.

SAFE TRANSPORTATION

- When towing a chipper the maximum speed limit is 60 mph.
- On rough or bumpy road surfaces reduce speed accordingly to protect your machine from unnecessary vibration.
- When towing off road be aware of objects that may catch the chipper undergear.
- When towing off road ensure inclination is not excessive.
- Avoid excessively pot holed ground.
- When reversing the chipper the short wheel base will react quickly to steering.
- Always check the discharge is tight before moving.
- Keep tyre pressures inflated to 1.8 bar or 26 psi.
- Check wheel nuts are tightened to 90nm or 65 lbs ft.
- Clear loose chippings and debris from the machine before departing.
- Ensure feed funnel is closed and the catch is properly engaged before departing.
- NEVER transport any items in feed funnel.
- Ensure tow hitch lock mechanism is locked before transporting.



HITCHING ONTO THE TOW BALL

- Check ball head is well greased.
- Wind jockey wheel assembly anticlockwise until the tow head is above the height of the ball hitch on the vehicle.
- Reverse vehicle so the ball hitch is directly below the tow head.
- Attach breakaway cable to a strong point on the vehicle, not the ball hitch.
- Grasp handle on tow head and push back catch with thumb.
- Wind jockey wheel assembly clockwise, to lower the tow head onto the ball hitch.
- Release handle and continue to wind jockey wheel clockwise. The tow head should snap into place on the ball hitch. If it doesn't, repeat previous 2 steps.
- Wind jockey wheel up until fully retracted and the jockey wheel frame is seated in its notch on the stem. The chipper weight should be fully on the vehicle.
- Check jockey wheel handle is secure before transportation. Do not overtighten jockey wheel handle.
- Release jockey wheel clamp and slide the jockey wheel assembly fully up.
- Tighten clamp on jockey wheel assembly.
- Connect electrical plug to socket on rear of towing vehicle and check operation of all the trailer and vehicle lights.
- The chipper is now properly attached to the vehicle.

UNHITCHING THE CHIPPER

- Ensure the chipper will not roll away after being disconnected from the vehicle.
- Disconnect the electrical cable from the vehicle socket and stow in the dock provided on the chassis when not in use.
- Release breakaway cable and stow in the dock provided on the chassis when not in use.
- Release the jockey wheel assembly clamp.
- Lower the jockey wheel assembly fully.
- Retighten the jockey wheel assembly clamp.
- Wind the jockey wheel assembly anticlockwise until it starts to take the weight of the chipper.
- Grasp the handle and release the catch with your thumb.
- Continue to wind the jockey wheel anticlockwise. This should lift the tow head clear of the ball hitch.
- Drive the vehicle clear of the chipper.
- Wind the jockey wheel assembly to a suitable point where the chipper is level. Do not overtighten jockey wheel handle.
- The chipper is now fully detached from the vehicle.

STORING THE CHIPPER

Perform the following tasks at the storage intervals indicated, following procedures described within this manual.

| Maintenance Tasks | Storage time | | | |
|---|--------------|------------|-------------|------------|
| | <1 month | 1-6 months | 6-12 months | >12 months |
| Allow the engine to cool down. | ✓ | ✓ | ✓ | ✓ |
| Clean the chipper, removing all woodchips. | ✓ | ✓ | ✓ | ✓ |
| Perform routine maintenance. | ✓ | ✓ | ✓ | ✓ |
| Check all fasteners and retighten. | ✓ | ✓ | ✓ | ✓ |
| Remove all fuel from the tank. NOTE: Either allow the machine to run until all fuel has been used, or drain from the plug provided. If necessary, siphon the fuel into an approved storage container (refer to re-fuelling section). Drain prior to moving machinery, to prevent spillage. | ✓ | ✓ | ✓ | ✓ |
| Disassemble the spark plug (petrol machines). | ✓ | ✓ | ✓ | ✓ |
| Where paint is damaged, touch up paint or treat with a lubricant. NOTE: Original paint colours are available from Timberwolf dealers. | ✓ | ✓ | ✓ | ✓ |
| Store the chipper in a dry place at +5°C to +40°C. NOTE: Timberwolf strongly recommends the machine is stored in a sheltered location, protected from rain. If the machine is stored outside, it must be well protected with tarpaulin. | X | ✓ | ✓ | ✓ |
| If relative humidity of the storage environment is > 60%, the shaft of the engine must be rotated by hand 1-2 revolutions bi-weekly. Prior to rotating the shaft, 20 to 30 ml of engine oil should be poured onto the bearing liner. | X | ✓ | ✓ | ✓ |
| Every 3 months, inspect the machine as per <1 month column. | X | X | ✓ | ✓ |
| Clean out and drain all lubrication lines, including grease pipes, fuel lines, oil reservoirs. Replace with new lubricants. NOTE: This should be performed at 6 month intervals (months 6 & 12) until re-commissioned. Drain prior to moving machinery, to prevent spillage. | X | X | ✓ | ✓ |
| Release and reapply handbrake to confirm it has not become sticky or faulty. | X | X | ✓ | ✓ |
| Check and restore tyre pressure levels. | X | X | ✓ | ✓ |
| Keep machine in original container/packaging or equivalent protection and store in a location free from extremes in temperature, at a min. temp. of +5°C and max. +40°C, humidity and corrosive environments. NOTE: If the storage location is cold, damp or severe humidity changes exist, adequate action should be taken to safeguard machinery. | X | X | X | ✓ |
| If machine is exposed to environmental conditions such as humidity during storage, inspect bearing lubrication system for presence of water. If water is detected in the lubricant, flush out the bearing housing and re-lubricate immediately. | X | X | X | ✓ |
| All breathers and drains are to be operable while in storage and/or the moisture drain plugs removed. The machinery must be stored so the drain(s) are at the lowest point, while the machine is in its stable position. | X | X | X | ✓ |
| Follow the recommissioning process before operation. | X | ✓ | ✓ | ✓ |

NOTE:

Regardless of storage time, all Timberwolf machines must be in a stable, level position when unhitched from a vehicle. Lower the Jockey wheel, unhitch and lower the prop stand, to ensure the machine is unable to roll or move unintentionally during storage. The discharge tube must be pointing towards the tow head. Braked machines should have the brake applied.

RECOMMISSIONING AFTER STORAGE

- Ensure machine is stable.
- Remove all guards and check all fasteners. If necessary, retighten as described within this manual.
- Ensure discharge tube is correctly fastened, free of objects or blockages and rotates around its pivot without being directed to face the point of operation (danger zone).
- Ensure feed funnel is free from foreign objects e.g. tools and clothing.
- Lower and raise feed funnel into its open and closed positions to confirm functionality.
- Check fuel within engine and top up accordingly. *
- Inspect all internal parts e.g. drive belts, taper locks and shaft keyways.
- Check belt tension as described within this manual.
- Inspect cutting blades to confirm they are sharp and suitable for use.
- Re-connect the battery to its positive and negative terminals.
- Undertake electrical diagnostic continuity check, to confirm circuit is complete.
- Check tyre pressures.
- Re-lubricate all grease pipes. Remove pipes and bleed the system prior to use, if necessary. *
- Follow daily checks before starting, as described within this manual.
- Start the machine.
- Run for 15 minutes at half throttle, prior to any cutting activity, to clear the combustion engine. Once complete, bring the machine onto full throttle for a further 5 minutes.

*Storage fluids should be replaced, DO NOT USE old stagnate fluids.

DELIVERY

All Timberwolf TW 18/100G machines have a full pre - delivery inspection before leaving the factory and are ready to use. Read and understand this instruction manual before attempting to operate the chipper. In particular, read pages 5-7 which contain important health and safety information and advice.

ENGINE CONTROLS

The engine speed is controlled by the vertically adjustable lever shown in diagram below. With the throttle lever in the FAST position the machine is ready to chip. It MUST be pushed up as far as possible to achieve a suitable working speed. If no wood is to be chipped for a few minutes the throttle should be returned to the idle position.

STARTING THE ENGINE

- Open fuel shutoff valve.
- Pull choke control to the full choke position.
- Move throttle lever to 'fast'. Always operate engine with throttle set to 'fast'.
- Push 'on/off' rocker switch to 'on' position.
- Insert key in ignition and turn to start engine.
- Release key as soon as engine starts.
- NOTE: To extend the life of the starter use only short starting cycles - 5 seconds max.
- Allow engine to warm up.
- In cold weather, allow engine to run smoothly before each change in the position of the choke handle. Operate with choke in 'run' position.
- In warm weather temperatures or recently operated conditions, move choke handle slowly in towards the 'run' position.

STOPPING THE ENGINE

- Move throttle lever to 'slow'
- Turn ignition key to 'off' position and remove.
- Close fuel shutoff valve.

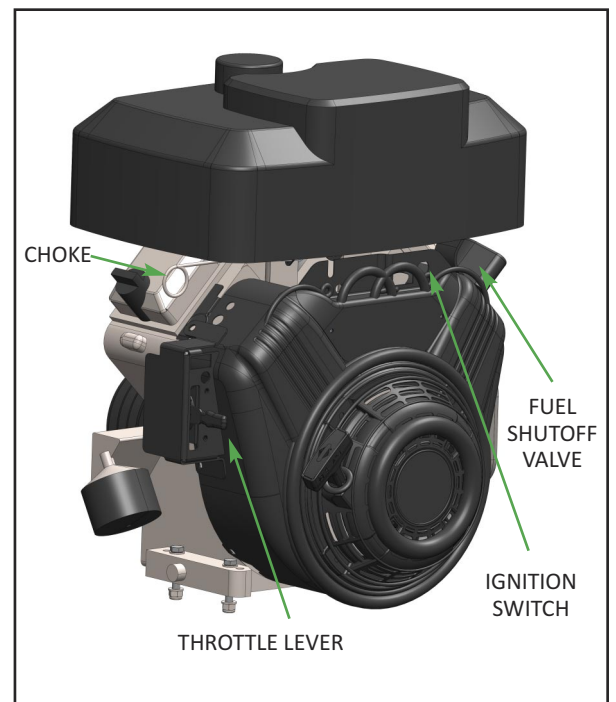

For more detailed information refer to the Engine Owner's Manual

EMERGENCY STOPPING

Should the machine need to be stopped in an emergency, push the **red emergency stop** button positioned on the funnel. This stops all power to the engine, bringing the machine to a complete stop. The engine cannot be restarted until the button is restored to its original position and the main ignition switch is turned off to reset the machine. Before disengaging the emergency stop button, ensure the engine has come to a complete standstill then inspect the machinery to determine the reason for activation.

DAILY CHECKS BEFORE STARTING

- Locate the machine on firm level ground.
- Check machine is well supported and cannot move.
- Check all guards are fitted and secure.
- Check the discharge unit is in place and fastened securely.
- Check discharge tube is pointing in a safe direction.
- Check the feed funnel to ensure no objects are inside.
- Check feed table is in up position - to prevent people reaching cutting blades.
- Check controls as described.
- Check (visually) for fluid leaks.
- Check fuel levels.

For parts location see diagrams on pages 3 & 4.



WARNING
DO NOT USE OR ATTEMPT TO START THE CHIPPER WITHOUT THE PROTECTIVE GUARDING AND DISCHARGE UNIT SECURELY IN PLACE. FAILURE TO DO SO MAY RESULT IN PERSONAL INJURY OR LOSS OF LIFE.

DISCHARGE CONTROLS

Controlling the discharge is an essential part of safe working.

ROTATION

- 1 Slacken nut using integral handle.
- 2 Rotate tube.
- 3 Retighten nut.

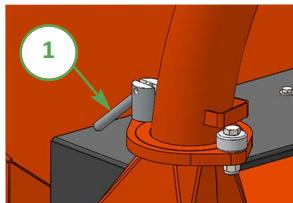

BUCKET ANGLE

Adjust the bucket to the desired angle using the handle provided.

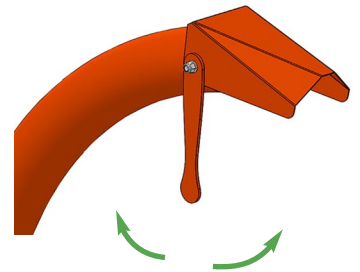

STARTING TO CHIP

- Check that the chipper is running smoothly.
- Stand to one side of the feed funnel.
- Proceed to feed material into the feed funnel.

CHIPPING

Wood up to the recommended diameter can be fed into the feed funnel. Enter it into the funnel butt end first. Release the material before it engages the rotor. Some pieces of wood may move around significantly while being chipped.

The wood will be drawn into the cutting blade quite quickly, be ready for this to happen. Stand well clear.

A piece of wood which is too tough or too large for the chipper will slow the engine down. When this happens it is possible to hold back the branches that are being chipped and allow the engine to regain its speed again.

If a piece of wood gets stuck in the funnel and it cannot be chipped due to its size or shape, it will need to be removed. Stop the engine and wait for moving parts to stop before removing the material. Trim the branch until it is a suitable shape for the chipper to accept.



WARNING
DO NOT USE OR ATTEMPT TO START THE CHIPPER WITHOUT THE PROTECTIVE GUARDING AND DISCHARGE UNIT SECURELY IN PLACE. FAILURE TO DO SO MAY RESULT IN PERSONAL INJURY OR LOSS OF LIFE.

BLOCKAGES

Always be aware that what you are putting into the chipper must come out. If the chips stop coming out of the discharge tube but the chipper is taking material in - STOP IMMEDIATELY. Continuing to feed material into a blocked machine may cause damage and will make it difficult to clear. If the chipper becomes blocked, proceed as follows:

- Stop the engine and remove the spark plug lead.
- Remove the discharge tube. Check that it is clear.
- Wearing gloves, reach into the rotor housing and scoop out the majority of the debris causing the blockage.
- Replace the discharge tube.
- Restart the engine and increase to full speed.
- Allow machine time to clear excess chips still remaining in rotor housing before you continue feeding brushwood.
- Feed in a small piece of wood while watching to make sure that it comes out of the discharge.
- If this does not clear it, repeat the process and carefully inspect the discharge tube to find any obstruction.



WARNING
DO NOT REACH INTO THE ROTOR HOUSING WITH UNPROTECTED HANDS. THERE ARE SHARP BLADES AND ANY SMALL MOVEMENT OF THE ROTOR MAY CAUSE SERIOUS INJURY.

NOTE

Continuing to feed the chipper with brushwood once it has become blocked will cause the chipper to compact the chips in the rotor housing and it will be difficult and time consuming to clear.

AVOID THIS SITUATION - WATCH THE DISCHARGE TUBE AT ALL TIMES.

BLADE WEAR

The most important part of using a wood chipper is keeping the cutter blades sharp. Timberwolf chipper blades are hollow ground to an angle of 40 degrees. When performing daily blade checks ensure blade edge is sharp and free from chips, if there is any evidence of damage, or the edge is "dull" change the blade(s). The TW 18/100G is fitted with 2 blades 177mm (7") long. They are 44 mm wide when new. A new blade should chip for up to 25 hours before it requires sharpening. This figure will be drastically reduced by feeding the machine with stony, sandy or muddy material.

As the blade becomes blunt, performance is reduced. With increased stress and load on the machine the chips will become more irregular and stringy. At this point the blade should be sent to a reputable blade sharpening company. The blade can be sharpened several times in its life. A wear mark indicates the safe limit of blade wear. Replace when this line is exceeded.

The machine is also fitted with a static blade (anvil). It is important that the anvil is in good condition to allow the cutting blades to function efficiently. Performance will be poor even with sharp cutter blades if the anvil is worn.

FUEL LEVEL INDICATOR

The fuel level can be seen through the wall of the plastic tank.

REFUELLING

When refuelling, follow standard Health & Safety practices:











- Stop the engine and allow to cool before refuelling.
- Never smoke or allow naked flames nearby while refuelling.
- Store fuel away from vapour ignition sources such as fires and people smoking.
- Never refuel at operating location, keep a distance of > 10 m to avoid creating fire hazards.
- Fuel storage containers must be approved for diesel fuel storage and clearly labelled with securely fitting caps.
- Clean area around fuel cap and use a funnel for refuelling. Replace the fuel cap securely. Do not fill the tank beyond the max. fill indicator.
- Avoid skin contact with fuel. If it gets into eyes wash out with sterile water immediately and seek medical advice as soon as possible.
- Always clean spillages quickly and change clothes before re-entering the work area if fuel is spilled onto garments.



TROUBLESHOOTING

This table is a troubleshooting guide to common problems.

If your problem is not listed below, or is unresolved after following the guide, please contact your Timberwolf service agent, whose Timberwolf trained engineers can perform further fault finding. Before you call, please have this operating manual and the machine serial number ready.

| Problem | Cause | Solution | Caution - Always ensure appropriate PPE is worn. | |
|--------------------------------------|----------------------|---|--|---|
| Wood chip ejection stopped / limited | Obstructed discharge | Clear debris from discharge chute. |  | Ensure machine is off and keys removed. |
| | Loose drive belts | Refer to manual & tension belts guidelines. |  | Ensure machine is off and keys removed. |
| | Broken rotor paddles | Inspect paddles, replace broken / missing paddle. |  | Ensure machine is off and keys removed. Call engineer for repair. |
| Rotor does not turn | Obstructed discharge | Clear debris from discharge chute. |  | Ensure machine is off and keys removed. |
| | Rotor jammed | Inspect & clear infeed funnel and rotor housing. |  | Ensure machine is off and keys removed. |
| | Drive belt issue | Inspect drive belts, replace if required. Refer to manual & tension belts guidelines. |  | Ensure machine is off and keys removed. |
| Slow or not feeding | Low engine speed | Check & inspect throttle and cable. Check throttle is set to specified speed. |  | Ensure machine is off and keys removed. |
| | Blades dull | Rotate, sharpen or replace blades. |  | Ensure machine is off and keys removed. |
| | Anvils dull | Check anvil has sharp edge, rotate, sharpen or replace if necessary. |  | Ensure machine is off and keys removed. |
| | Obstructed discharge | Clear debris from discharge chute. |  | Ensure machine is off and keys removed. |



THE FOLLOWING PAGES DETAIL ONLY BASIC MAINTENANCE GUIDELINES SPECIFIC TO YOUR CHIPPER.



THIS IS NOT A WORKSHOP MANUAL.

The following guidelines are not exhaustive and do not extend to generally accepted standards of engineering/mechanical maintenance that should be applied to any piece of mechanical equipment and the chassis to which it is mounted.

Authorised Timberwolf service agents are fully trained in all aspects of total service and maintenance of Timberwolf wood chippers. You are strongly advised to take your chipper to an authorised agent for all but the most routine maintenance and checks.

Timberwolf accepts no responsibility for the failure of the owner/user of Timberwolf chippers to recognise generally accepted standards of engineering/mechanical maintenance and apply them throughout the machine.

The failure to apply generally accepted standards of maintenance, or the performance of inappropriate maintenance or modifications, may invalidate warranty and/or regulatory compliance, in whole or in part.

Please refer to your authorised Timberwolf service agent for service and maintenance.

SERVICE SCHEDULE



WARNING

ALWAYS IMMOBILISE THE MACHINE BY STOPPING THE ENGINE, REMOVING THE IGNITION KEY AND DISCONNECTING THE BATTERY BEFORE UNDERTAKING ANY MAINTENANCE WORK.

| SERVICE SCHEDULE | Daily Check | 25 Hours | 50 Hours | 100 Hours | 250 Hours |
|---|--|----------|----------|-----------|-----------|
| Check engine oil - top up if necessary (10W-30). | ✓ | | | | |
| Check fuel level. | ✓ | | | | |
| Check feed funnel, access cover, belt guard and discharge unit are securely fitted. | ✓ | | | | |
| Check tyre pressure is 1.8 Bar (26 psi). | ✓ | | | | |
| Check funnel flange and front face. | | ✓ | | | |
| Check for tightness front and rear bearing retaining nuts. | | ✓ | | | |
| Check for tightness spindle screw in centre of front bearing. | | ✓ | | | |
| Check for tightness engine mount bolts. | | ✓ | | | |
| Check tension of main drive belts (and tension if necessary). | | ✓ | | | |
| Clean air filter foam pre cleaner. | | ✓ | | | |
| Check machine to ensure nothing has worked loose. | | ✓ | | | |
| Change blades if necessary. | | ✓ | | | |
| Check wheel nuts are tight. | | ✓ | | | |
| Check all bolts retaining chipper to chassis. | | ✓ | | | |
| Repeat 25 hour service. | | | ✓ | | |
| Change oil. | | | ✓ | | |
| Check anvil for wear. | | | ✓ | | |
| Repeat 25 & 50 hour service. | | | | ✓ | |
| Replace oil filter. | | | | ✓ | |
| Inspect air filter - replace if necessary. | | | | ✓ | |
| Check battery electrolyte level . | | | | | ✓ |
| Repeat 25 & 50 hour service. | | | | | ✓ |
| Change spark plugs. | | | | | ✓ |
| Replace anvil when worn. | RETURN TO DEALER FOR ANVIL CHANGE | | | | |

SAFE MAINTENANCE

- Handle blades with extreme caution to avoid injury. Gloves should always be worn when handling the cutter blades.
- The drive belts should be connected while changing blades, as this will restrict sudden movement of the rotor.
- The major components of this machine are heavy. Lifting equipment must be used for disassembly.
- Clean machines are safer and easier to service.
- Avoid contact with hazardous materials.



WARNING

ALWAYS IMMOBILISE THE ENGINE BEFORE UNDERTAKING ANY MAINTENANCE WORK ON THE CHIPPER BY REMOVING THE IGNITION KEY AND DISCONNECTING THE BATTERY. ENSURE THE CHIPPER IS STABLE BEFORE PERFORMING ANY MAINTENANCE.

SAFE LIFTING OF THE CHIPPER

The lifting eye is designed to lift the machine’s weight only. Do not use hoist hook directly on the lifting eye, use a correctly rated safety shackle. Inspect the lifting eye prior to each use - **DO NOT USE LIFTING EYE IF DAMAGED**. Maximum lift weight is 850kg, as indicated on the machine.



SPARES

Only fit genuine Timberwolf replacement blades, screws and chipper spares. Failure to do so will result in the invalidation of the warranty and may result in damage to the chipper, personal injury or even loss of life.

BATTERY REMOVAL AND MAINTENANCE

- 1 The battery is located under the funnel.
- 2 Remove the negative lead first and then the positive lead.
- 3 Clean, charge and/or top up the battery as required.
- 4 Refitting is the reverse of removal. Apply a smear of petroleum jelly to the terminals to prevent corrosion.



WARNING

REFER TO THE BATTERY SAFETY SECTION ON PAGE 16.

CHECK FITTINGS

The Timberwolf TW 18/100G is subject to large vibrations during the normal course of operation. Consequently there is always a possibility that nuts and bolts will work themselves loose. It is important that periodic checks are made to ensure the security of all fasteners. Fasteners should be tightened using a torque wrench to the required torque (see below). **Uncalibrated torque wrenches can be inaccurate by as much as 25%. It is therefore essential that a calibrated torque wrench is used to achieve the tightening torques listed below.**

| | Size | Pitch | Head | Torque lb/ft | Torque Nm |
|-------------|------|----------|-----------|--------------|-----------|
| Blade Bolts | M8 | Standard | T40 Torq | 22 | 30 |
| General | M8 | Standard | 13 mm Hex | 20 | 27 |
| General | M10 | Standard | 17 mm Hex | 45 | 61 |
| General | M12 | Standard | 19 mm Hex | 65 | 88 |

HAZARDOUS MATERIALS & END OF MACHINE LIFE

During Machine Life

The following hazardous materials are supplied within Timberwolf machines:

- Engine oil
- Battery acid
- Diesel
- Copper Ease

MATERIAL SAFETY DATA SHEETS FOR HAZARDOUS MATERIALS SUPPLIED WITHIN TIMBERWOLF MACHINES ARE AVAILABLE ON REQUEST. REFER TO THESE FOR FIRST AID AND FIRE PROTECTION MEASURES.

Always follow recommended procedures for safe handling, removal and disposal of hazardous materials. Safety precautions should be taken when handling hazardous materials (use of oil-resistant gloves and safety glasses are recommended - respiratory protection is not required). Avoid direct contact with the substance and store in a cool, well ventilated area avoiding sources of ignition, strong oxidising agents and strong acids. Ensure hazardous spillages do not flow into the ground or drainage system and ensure potential environmental damage is controlled safely, according to local laws.

End of Machine Life

Follow these guidelines using approved local waste and disposal agencies for recycled materials, according to applicable Health, Safety and Environmental laws.











- Position the machine within reach of all necessary lifting equipment.
- Use tools and PPE detailed within maintenance instructions.
- Remove all hazardous materials and battery and store safely before disposal.
- Disassemble the machine structure, referring to the maintenance instructions. Pay attention to parts with mechanical pressure or tension applied, including springs.
- Separate items that continue to have a service life.
- Separate worn items into material groups and where possible, recycle using available agencies for recycled materials. Common types are:

| | |
|--------------------|---|
| Steel | Plastic materials |
| Non-ferrous metals | Rubber |
| Aluminium | Electrical and Electronic Components |
| Brass | Other materials that can be recycled |
| Copper | Other materials that cannot be recycled |

- If a part is not easily separated into different material groups, it must be added to “general discarded materials”.
- Do not burn discarded materials.
- Change the machinery records to show that the machine is out of service and discarded. Supply this serial number to Timberwolf to close their records.

BATTERY SAFETY INFORMATION

WARNING NOTES AND SAFETY REGULATIONS FOR FILLED LEAD-ACID BATTERIES

| | | | | | |
|--|--|---|---|---|---|
|  | <ul style="list-style-type: none"> For safety reasons, wear eye protection when handling a battery. |  | <p>Corrosive hazard: Battery acid is highly corrosive, therefore:</p> <ul style="list-style-type: none"> Wear protective gloves and eye protection. Do not tilt the battery, acid may escape from the vent openings. |  | <ul style="list-style-type: none"> If acid is swallowed, consult a doctor immediately. |
|  | <ul style="list-style-type: none"> Keep out of reach of children. | | | | <p>Warning notes: The battery case can become brittle, to avoid this:</p> <ul style="list-style-type: none"> Do not store batteries in direct sunlight. |
|  | <ul style="list-style-type: none"> Fires, sparks, naked flames and smoking are prohibited. | | | | <ul style="list-style-type: none"> Discharged batteries may freeze up, therefore store in an area free from frost. |
|  | <ul style="list-style-type: none"> Avoid causing sparks when dealing with cables and electrical equipment, and beware of electrostatic discharges. |  | <p>First aid:</p> <ul style="list-style-type: none"> Rinse off acid splashed in the eyes immediately for several minutes with clear water! Remove contact lenses if worn and continue rinsing. Then consult a doctor immediately. | | <p>Disposal:</p> <ul style="list-style-type: none"> Dispose of old batteries at an authorised collection point. |
|  | <p>Explosion hazard:</p> <ul style="list-style-type: none"> A highly explosive oxyhydrogen gas mixture is produced when batteries are charged. | | <ul style="list-style-type: none"> Neutralise acid splashes on the skin or clothes immediately with acid neutraliser (soda) or soap suds, and rinse with plenty of water. |  | <ul style="list-style-type: none"> The notes listed under item 1 are to be followed for transport. |
| | | | |  | <ul style="list-style-type: none"> Never dispose of old batteries in household waste. |

1. Storage and transport

- Batteries are filled with acid.
- Always store and transport batteries upright and prevent from tilting so that no acid can escape.
- Store in a cool and dry place.
- Do not remove the protective cap from the positive terminal.
- Run a FIFO (first in-first out) warehouse management system.

2. Initial operation

- The batteries are filled with acid at a density of 1.28g/ml during the manufacturing process and are ready for use.
- Recharge in case of insufficient starting power (see no. 4).

3. Installation in the vehicle and removal from the vehicle

- Switch off the engine and all electrical equipment.
- When removing, disconnect the negative terminal first.
- Avoid short circuits caused by tools, for example.
- Remove any foreign body from the battery tray, and clamp battery tightly after installation.
- Clean the terminals and clamps, and lubricate slightly with battery grease.
- When installing, first connect the positive terminal, and check the terminal clamps for tight fit.
- After having fitted the battery in the vehicle, remove the protective cap from the positive terminal, and place it on the terminal of the replaced battery in order to prevent short circuits and possible sparks.
- Use parts from the replaced battery, such as the terminal covers, elbows, vent pipe connection and terminal holders (where applicable); use available or supplied filler caps.
- Leave at least one vent open, otherwise there is a danger of explosion. This also applies when old batteries are returned.

4. Charging

- Remove the battery from the vehicle; disconnect the lead of the negative terminal first.
- Ensure good ventilation.
- Use suitable direct current chargers only.
- Connect the positive terminal of the battery to the

positive output of the charger. Connect the negative terminal accordingly.

- Switch on the charger only after the battery has been connected, and switch off the charger first after charging has been completed.
- Charging current-recommendation: 1/10 ampere of the battery capacity Ah.
- Use a charger with a constant charging voltage of 14.4V for re-charging.
- If the acid temperature rises above 55° Celsius, stop charging.
- The battery is fully charged when the charging voltage has stopped rising for two hours.

5. Maintenance

- Keep the battery clean and dry.
- Use a moist anti-static cloth only to wipe the battery, otherwise there is a danger of explosion.
- Do not open the battery.
- Recharge in case of insufficient starting power (see no. 4).

6. Jump Starting

- Use the standardised jumper cable in compliance with DIN 72553 only, and follow the operating instructions.
- Use batteries of the same nominal voltage only.
- Switch off the engines of both vehicles.
- First connect the two positive terminals (1) and (2), then connect the negative terminal of the charged battery (3) to a metal part (4) of the vehicle requiring assistance away from the battery.
- Start the engine of the vehicle providing assistance, then start the engine of the vehicle requiring assistance for a maximum of 15 seconds.
- Disconnect the cables in reverse sequence (4-3-2-1).

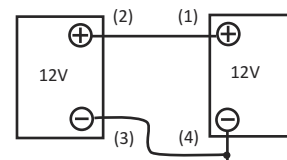

7. Taking the battery out of service

- Charge the battery; store in a cool place or in the vehicle with the negative terminal disconnected.
- Check the battery state of charge at regular intervals, and correct by recharging when necessary (see no. 4).

CHANGE BLADES

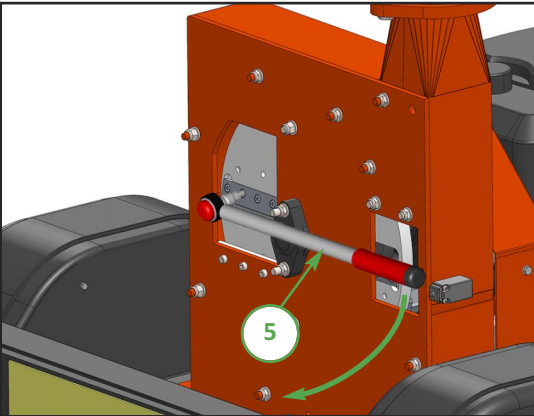
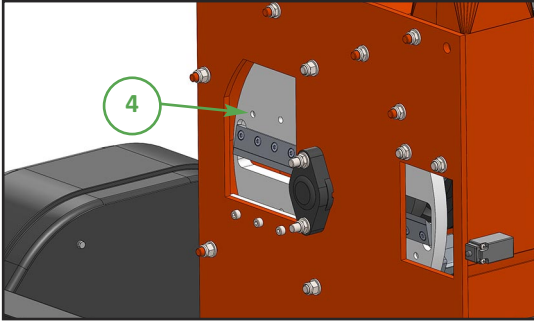

WARNING

WEAR RIGGERS GLOVES FOR THE BLADE CHANGING OPERATION.

- 1 Turn the chipper off and remove the spark plug lead.
- 2 Remove the feed funnel.
- 3 Remove blade access cover.
- 4 Insert M10 screw into rotor to stop it turning.
- 5 Using the Torx fitting provided loosen the blade screws.
- 6 Remove the blade carefully.
- 7 **Before fitting a new blade ensure the seating surface on the rotor is spotlessly clean. This is necessary to ensure the blade is always held firm. Damage to the rotor may be caused if this is not checked.**
- 8 Apply a small amount of copper grease to the blade screws.
- 9 **Using a torque wrench tighten the blade screws to 29 Nm (22 lb/ft).**
- 10 Remove the M10 screw securing the rotor.
- 11 Re-install blade access cover.
- 12 Re-install the feed funnel.

WARNING

ALWAYS SHARPEN BLADES ON A REGULAR BASIS. FAILURE TO DO SO WILL CAUSE THE MACHINE TO UNDER PERFORM AND WILL OVERLOAD ENGINE AND BEARINGS CAUSING MACHINE BREAKDOWN. BLADES MUST NOT BE SHARPENED BEYOND THE WEAR MARK (SEE DIAGRAM). FAILURE TO COMPLY WITH THIS COULD RESULT IN MACHINE DAMAGE, INJURY OR LOSS OF LIFE.

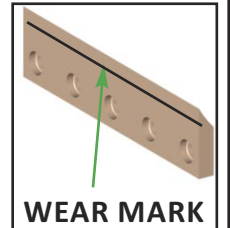

TENSION DRIVE BELTS

NOTE: There will normally be a rapid drop in tension during run-in period for new belts. When new belts are fitted, check the tension every 2 - 3 hours and adjust until the tension remains constant. Belt failures due to lack of correct tensioning will not be covered under your Timberwolf warranty.

- 1 Remove belt guard.
- 2 Loosen bolt in centre of tensioner pulley with a 19 mm spanner so that pulley is able to slide with minimal wobble.
- 3 Turn nut in end of tensioner pulley slider until correct belt tension is achieved. For instructions on checking belt tension & correct belt tension values, please refer to the Timberwolf V-Belt Tensioning Data Table (pg 24).
- 4 Re-tighten bolt in centre of tensioner pulley.
- 5 Re-install belt guard.
- 6 Run machine and test, recheck belt tension.

NOTE: Slack drive belts will cause poor performance and belt / pulley wear.

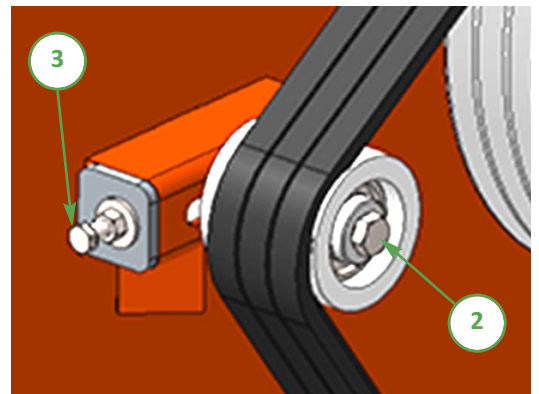

GREASE THE DISCHARGE FLANGE

- 1 Remove the discharge tube.
- 2 Apply multipurpose grease to surface shown.
- 3 Refit discharge tube.

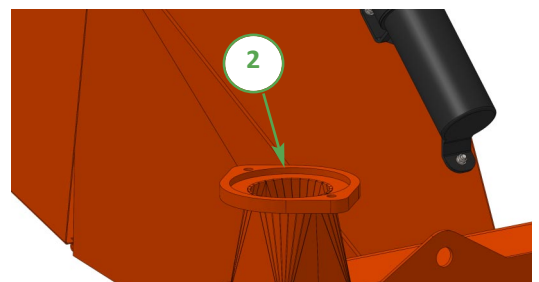

ENGINE SERVICING

All engine servicing must be performed in accordance with the Engine Manufacturer's Handbook provided with the machine. **Failure to adhere to this may invalidate warranty and/or shorten engine life.**

TIMBERWOLF NO-NONSENSE WARRANTY

All new Timberwolf machines come with peace of mind built in. Our no-nonsense warranty is your guarantee of your Timberwolf wood chipper not letting you down.

Your warranty statement is included in your manual pack. Please ensure you register your machine with your dealer to ensure you are eligible for the full Timberwolf warranty period.



Environmental Manufacturing LLP

Entec House,
Tomo Industrial Estate,
Stowmarket,
Suffolk IP14 5AY
Tel: 01449 765800 Fax: 01449 765801

E C Declaration of Conformity



Environmental Manufacturing LLP as the designer and manufacturer, certifies that the machine stipulated below complies with all the relevant provisions of the:

Machinery Directive; 2006/42/EC (& other relevant directives)

and the National Laws and Regulations adopting these directives.

Designer/Manufacturer : Environmental Manufacturing LLP

Description of Machinery : Self-powered portable machine intended to chip up tree waste prior to disposal.

Model : TW 18/100G

Serial No. Serial Manufacture

BSI Transposed Harmonised Standards applied: (including parts/clauses of):

BS EN 12100-1: 2010 Safety of Machinery- Basic concepts, BS EN 13857-1: 2008 Safety of Machinery-Safety distances to danger zones, BS EN 60204-1: 2006 +A1 2009 Safe electrical practices, BS EN 13732-1:2008 Safety of Machinery – Temperatures of touchable surfaces, BS EN 13849-1: 2008 – Safety of Machinery – Safety related parts of control systems, BS13850:2008 safety of Machinery Emergency stop BS EN 982: 1996 + A1 2005 – Safety of Machinery – Hydraulics, BS EN 1088: 1995 + A2 2008 – Safety of Machinery – Interlocking devices, BS EN 13525: 2005 + A2 2009 – Forestry Machinery – Wood chippers – Safety. BS EN 953:1997+A1:2009



“Responsible” Person empowered to sign:
Position in Company:

Managing Director











Mr. Chris Perry

Date:

5th July 2018

| | | | |
|---|--|--|---|
|  | | TIMBERWOLF ENVIRONMENTAL MANUFACTURING LLP Entec House, Tomo Industrial Estate, Stowmarket, Suffolk IP14 5AY - UK |  |
| MODEL | | | |
| SERIAL NO. | | | |
| CARR. TYP/SN. | | CROSS WEIGHT | |
| NOM. PWR | | DATE | |
| | | | ENVIRONMENTAL MANUFACTURING LLP |
| | | | |
| | | | |
| | | | |
| | | | 0 - KG |
| | | | 1 - KG |
| | | | 2 - KG |

EXAMPLE

| Decal | Description | Decal | Description |
|---|---|--|---|
|  <p>616</p> | <p>Warning. Hot exhaust.</p> |  <p>18393</p> | <p>New drive belts need re-tensioning. When new belts are fitted check tension every 2-3 hours & adjust until tension remains constant.</p> |
|  <p>617</p> | <p>Warning. High velocity discharge - keep clear.</p> |  <p>2949</p> | <p>Lifting eye is designed to lift the machine's weight only. Do not use hoist hook directly on lifting eye. Use correctly rated safety shackle only through lifting eye. Lifting eye to be inspected every 6 months or before each use. Always visually inspect lifting eye prior to each use. Do not use lifting eye if damaged.</p> |
|  <p>655</p> | <p>Caution. Avoid standing directly in front of feed funnel to reduce exposure to noise, dust and risk from ejected particles.</p> |  <p>3022</p> | <p>Clean under blades before refitting or turning. Failure to do so may result in blade(s) coming loose and damage being caused to the rotor housing.</p> |
|  <p>1662</p> | <p>The instruction manual with this machine contains important operating, maintenance and health and safety information. Failure to follow the information contained in the instruction manual may lead to death or serious injury.</p> |  <p>P637 x 3</p> | <p>Danger. Do not operate without this cover in place.</p> |
|  <p>4099</p> | <p>Danger. Rotating blades. Keep hands and feet out.</p> |  <p>670</p> | <p>Personal Protective Equipment required. See Page 5.</p> |

| Decal | Description | Decal | Description |
|-------------|--|------------------|--|
| <p>P656</p> | <p>Danger. Do not use this machine without the discharge unit fitted. Failure to comply may result in serious injury or damage.</p> | <p>P653</p> | <p>Danger. Rotating blades inside. Stop engine and remove key before removing discharge unit.</p> |
| <p>P652</p> | <p>Caution. Do not put road sweepings in machine as grit will damage blades.</p> | <p>P654</p> | <p>Caution. When transporting, discharge clamps may work loose. Check frequently.</p> |
| <p>P651</p> | <p>Fuel Here. Risk of fire. Allow engine to cool for 1 minute before refuelling. Use unleaded petrol.</p> | <p>C192-0102</p> | <p>Do not climb into the funnel.</p> |

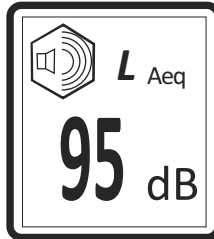

1363

3012

3013

1849



TIMBERWOLF
TW 18/100G

17862 x 2

P*154

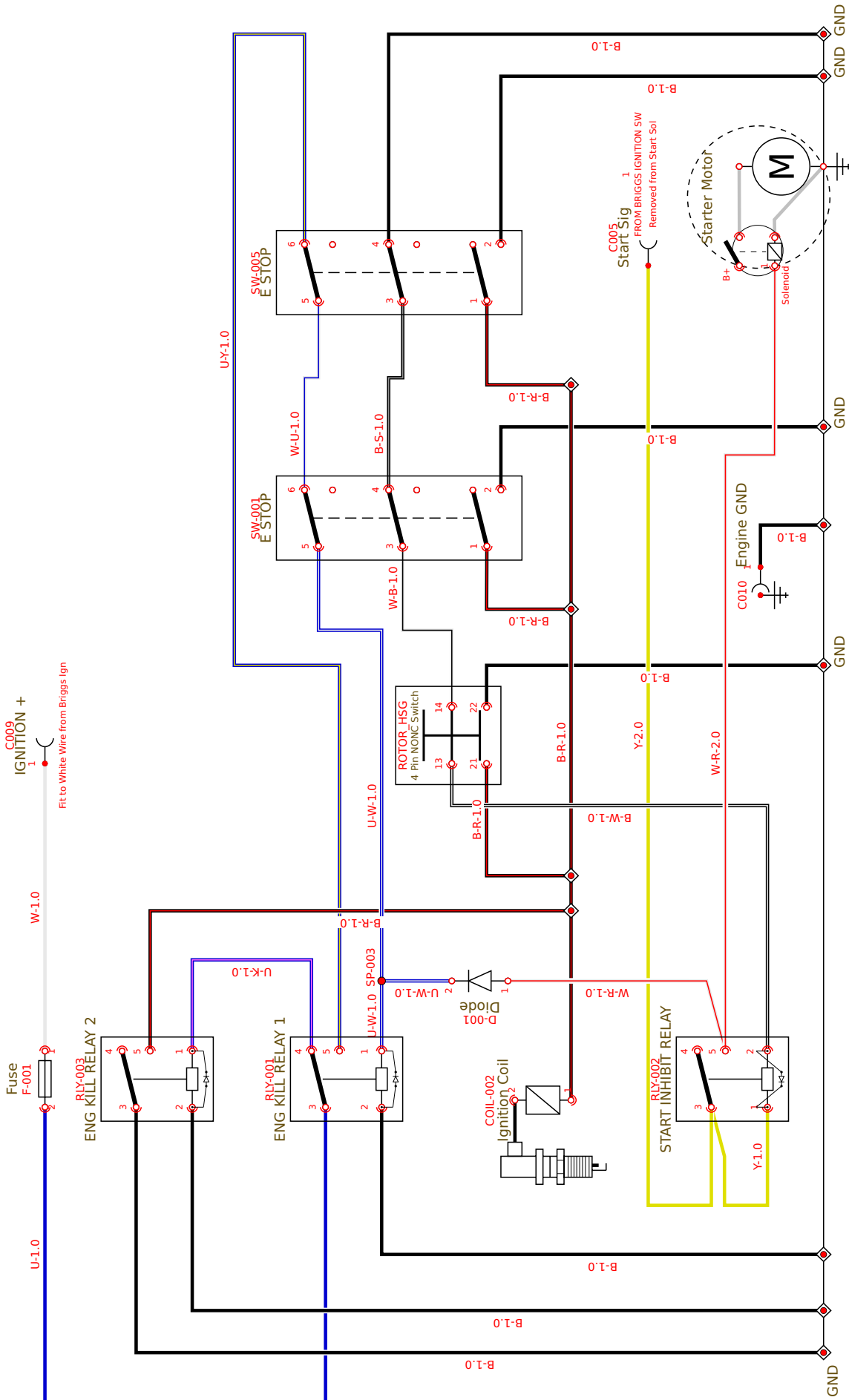

Method:

- 1 Set the deflection distance on the lower scale of the tension gauge so that the underside of the 'o'-ring equals the 'h' value given in the table.
- 2 Ensure that the deflection force scale is zero'd by pushing the upper 'o'-ring all the way down.
- 3 Place the tension gauge in the centre of the belt span as shown in the diagram.
- 4 Press downwards on the rubber buffer, deflecting the belt until the underside of the lower 'o'-ring is level with the belt behind (use a straight edge if there is only 1 belt).
- 5 Take the reading from the deflection scale of the tension meter (read at the lower edge of the 'o'-ring) & compare this value with that given in the table.
- 6 Tighten or loosen belts as required following procedure given in this operator's manual.

Tension gauges are available from Timberwolf spares, quoting part no. 18091

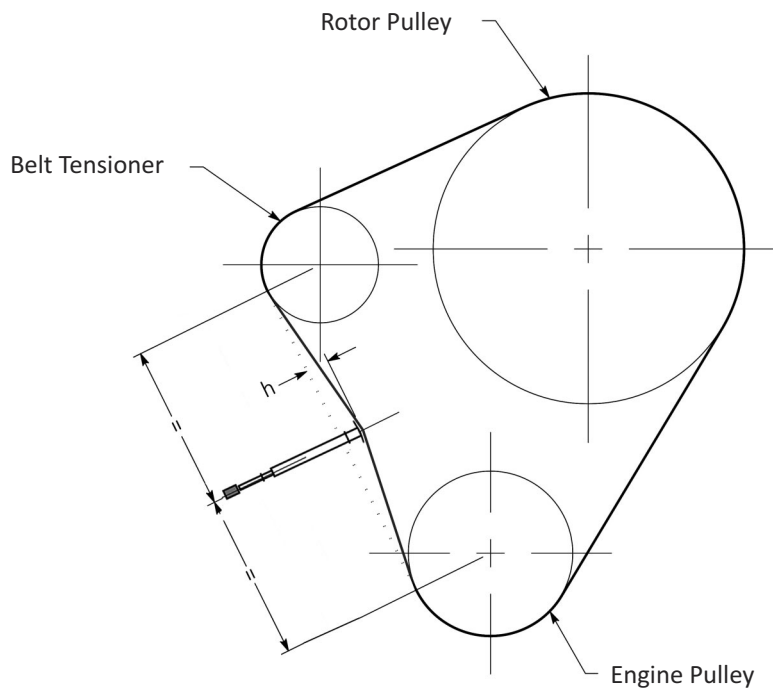

| TW 18/100G | | Rotor Belts |
|------------------------|-----------|-------------------|
| Belt Mftr / Type | | Gates Super HC-MN |
| Belt Pitch Designation | | SPA |
| Belt Length in mm | | 1060 |
| Belt Deflection in mm | = h | 2.1 |
| Force Reading (Kg) | New belt | 1.3 |
| | Used Belt | 1.1-1.2 |

Tips on belt tightening:

- There will normally be a rapid drop in tension during the run-in period for new belts. When new belts are fitted, check the tension every 2-3 hours & adjust until the tension remains constant.
- The best tension for V-belt drives is the lowest tension at which the belts do not slip or ratchet under the highest load condition.
- Too much tension shortens belt & bearing life.
- Too little tension will affect the performance of your machine especially in respect of no-stress devices.
- Ensure that belt drives are kept free of any foreign materials.
- If a belt slips - tighten it!

| | | | |
|--|--|------------------------|--|
| Model number: | | Serial number: | |
| Date of delivery/ handover: | | Options/extras: | |
| Dealer pre delivery check: | | | |
| Inspected by: | | | |

| | |
|---------------------------------------|--------------------------------|
| 50 HOUR WARRANTY SERVICE CHECK | Authorised dealer stamp |
| Date: | |
| Hours: | |
| Invoice number: | |
| Signature: | |
| Next service due: | |

| | |
|--|--------------------------------|
| 11 MONTH WARRANTY SERVICE CHECK | Authorised dealer stamp |
| Date: | |
| Hours: | |
| Invoice number: | |
| Signature: | |
| Next service due: | |

| | |
|--|--------------------------------|
| 23 MONTH WARRANTY SERVICE CHECK | Authorised dealer stamp |
| Date: | |
| Hours: | |
| Invoice number: | |
| Signature: | |
| Next service due: | |

| | |
|--------------------------|--------------------------------|
| Date: | Authorised dealer stamp |
| Hours: | |
| Invoice number: | |
| Signature: | |
| Next service due: | |

| | |
|--------------------------|--------------------------------|
| Date: | Authorised dealer stamp |
| Hours: | |
| Invoice number: | |
| Signature: | |
| Next service due: | |

| | |
|--------------------------|--------------------------------|
| Date: | Authorised dealer stamp |
| Hours: | |
| Invoice number: | |
| Signature: | |
| Next service due: | |

| | |
|--------------------------|--------------------------------|
| Date: | Authorised dealer stamp |
| Hours: | |
| Invoice number: | |
| Signature: | |
| Next service due: | |

PARTS LISTS

THE FOLLOWING ILLUSTRATIONS ARE FOR PARTS IDENTIFICATION ONLY. THE REMOVAL OR FITTING OF THESE PARTS MAY CAUSE A HAZARD AND SHOULD ONLY BE CARRIED OUT BY TRAINED PERSONNEL.

| | Page No. |
|-------------------|----------|
| BELT TENSIONER | 28 |
| CHASSIS | 29 |
| CHASSIS - DRAWBAR | 30 |
| DISCHARGE | 31 |
| ENGINE | 32 |
| FUNNEL & GUARDS | 33 |
| ROTOR | 34 |
| ROTOR HOUSING | 35 |
| DECALS | 36 |

| ITEM NO. | PART NUMBER | DESCRIPTION | QTY. |
|----------|-------------|-------------------------------------|------|
| 1 | 0411M | Pulley Tension Outer | 1 |
| 2 | 0472M | Pulley Tension Boss | 1 |
| 3 | C128-0105 | Bearing 6205 2Rs C3 | 2 |
| 4 | 0469MS | Block Pulley Tension Adjuster | 1 |
| 5 | 1342PS | Plate Block Pulley Tension Adjuster | 1 |
| 6 | C002-0622 | M8 x 90 HEX SET Z/P 8.8 | 2 |
| 7 | C030-0123 | M8 HEX NUT - ZP - GRADE 10 | 1 |
| 8 | C024-0103 | Large Washer M8 BZP | 1 |
| 9 | 19758_C | Bracket Slide Tension Pulley | 1 |
| 10 | 0415M | Heavy Washer M12 | 1 |

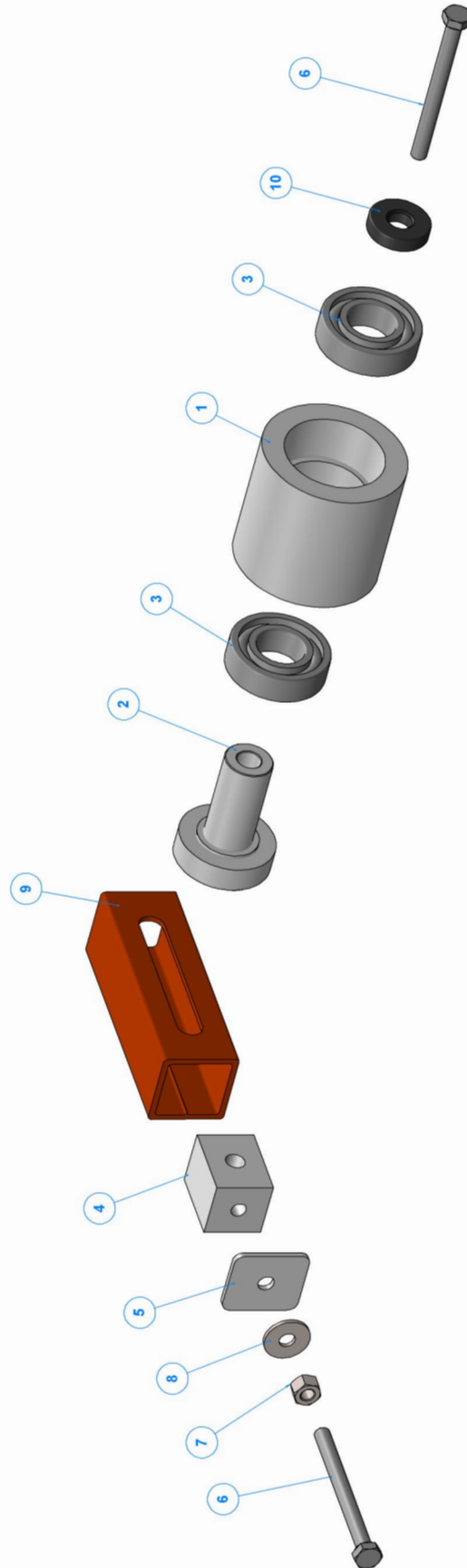

| ITEM NO. | PART NUMBER | DESCRIPTION | QTY. |
|----------|-------------|---------------------------------------|------|
| 1 | C021-0127 | M12 FORM C WASHER ZIP | 4 |
| 2 | C002-0826 | M12 x 120 HEX SET ZIP 8.8 | 2 |
| 3 | C031-0125 | M12 TYPE T NYLOC NUT ZIP | 2 |
| 4 | C002-0407 | M6 x 20 HEX SET ZIP 8.8 | 8 |
| 5 | C021-0123 | M6 FORM C WASHER ZIP | 8 |
| 6 | WA710 | M6 x 24 Washer BZP | 8 |
| 7 | C031-0161 | M6 TYPE P NYLOC NUT ZIP | 8 |
| 8 | Wheel bolt | Boit M12 1.5 Wheel - Supp'd with axle | 8 |
| 9 | C013-0307 | M5 x 20 PAN POZI ZIP | 2 |
| 10 | C021-0102 | M5 FORM A WASHER ZIP | 2 |
| 11 | C031-0160 | M5 TYPE P NYLOC NUT ZIP | 2 |
| 12 | C002-0609 | M8 x 25 HEX SET ZIP 8.8 | 4 |
| 13 | C031-0123 | M8 TYPE T NYLOC NUT ZIP | 6 |
| 14 | C021-0125 | M8 FORM C WASHER ZIP | 12 |
| 15 | C002-0612 | M8 x 40 HEX SET ZIP 8.8 | 2 |
| 16 | 19792 | Lightboard | 1 |
| 17 | 19764F | Chassis Assembly | 1 |
| 18 | 17516 | Axle TW18/100G | 1 |
| 19 | C031-0163 | M8 TYPE P NYLOC NUT ZIP | 2 |
| 20 | C021-0125 | M8 FORM C WASHER ZIP | 2 |
| 21 | C024-0103 | Large Washer M8 BZP | 2 |
| 22 | C002-0610 | M8 x 30 HEX SET ZIP 8.8 | 2 |
| 23 | Mudguard | Mudguard OS | 1 |
| 24 | 19691 | Rain Flap | 1 |
| 25 | 19681 | Rain Flap Clamp | 1 |
| 26 | 19689 | Profile Rain Flap | 1 |
| 27 | C002-0610 | M8 x 30 HEX SET ZIP 8.8 | 2 |
| 28 | C031-0163 | M8 TYPE P NYLOC NUT ZIP | 2 |
| 29 | C021-0125 | M8 FORM C WASHER ZIP | 2 |
| 30 | C024-0103 | Large Washer M8 BZP | 2 |
| 31 | 19775 | N/S Mudguard | 1 |
| 32 | 19681 | Rain Flap Clamp | 1 |
| 33 | 19691 | Rain Flap | 1 |
| 34 | 19689 | Profile Rain Flap | 1 |
| 35 | 19663 | 13 Inch Wheel Assy | 2 |
| 36 | 19742 | Anti Trap Bar | 1 |
| 37 | 18922 | REFLECTOR CLEAR ROUND FRONT | 2 |
| 38 | 4210 | Battery 12V | 1 |
| 39 | 0764 | Battery Box Half Section | 2 |
| 40 | 1808F | Flat profile for 1808F | 1 |

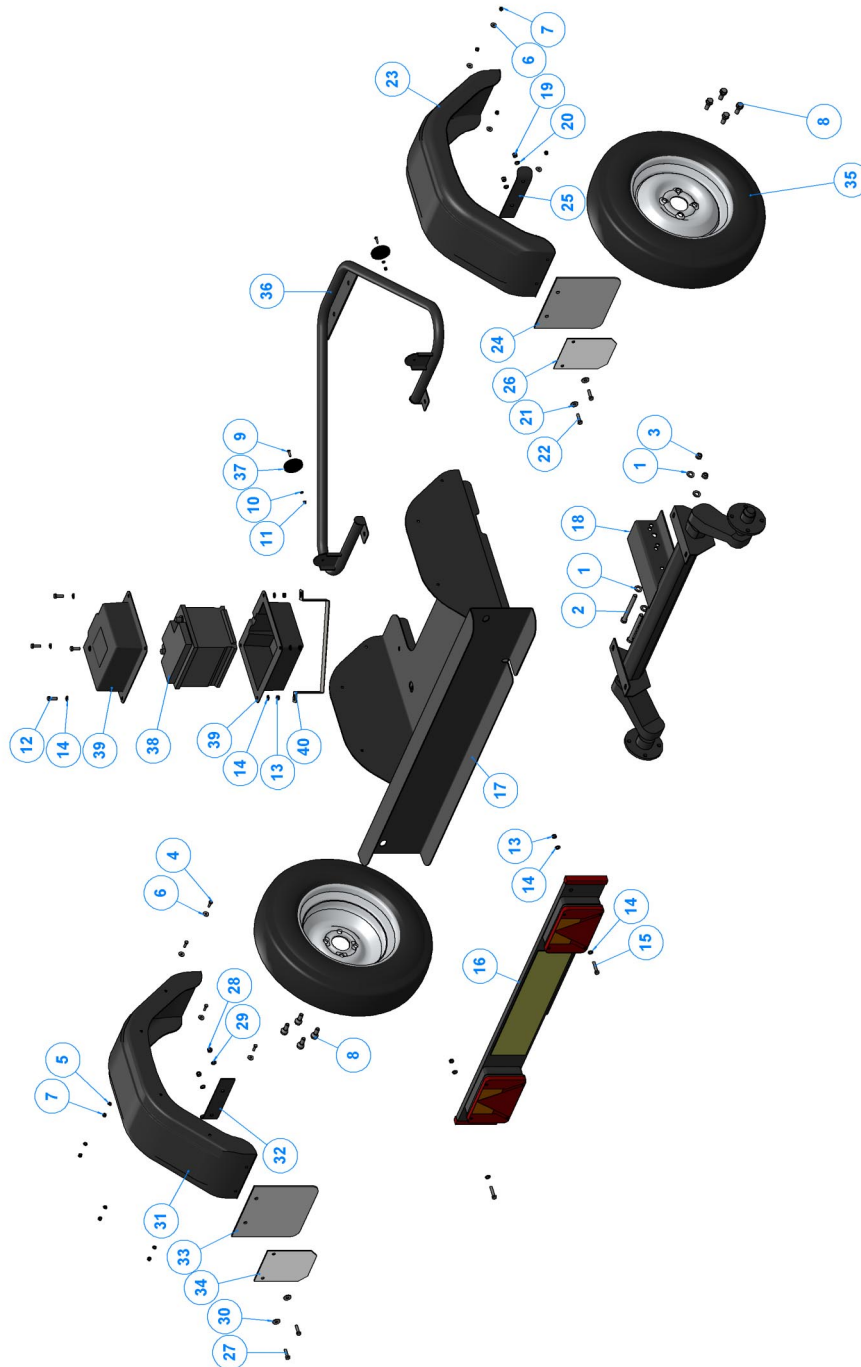

| ITEM NO. | PART NUMBER | DESCRIPTION | QTY. |
|----------|-------------|---------------------------|------|
| 1 | C002-0824 | M12 x 100 HEX SET Z/P 8.8 | 2 |
| 2 | C021-0107 | M12 FORM A WASHER Z/P | 4 |
| 3 | C031-0165 | M12 TYPE P NYLOC NUT Z/P | 6 |
| 4 | C002-0710 | M10 x 30 HEX SET Z/P 8.8 | 2 |
| 5 | C021-0106 | M10 FORM A WASHER Z/P | 4 |
| 6 | C031-0164 | M10 TYPE P NYLOC NUT Z/P | 2 |
| 7 | 17518 | Swan Neck | 1 |
| 8 | 0018 | Tow Hitch Safety Cable | 1 |
| 9 | 17611 | Skid Plate | 1 |
| 10 | 17515 | Jockey Wheel Clamp | 1 |
| 11 | P0000075 | Jockey Wheel | 1 |
| 12 | 19797 | Saddle Bracket | 2 |
| 13 | C002-0814 | M12 x 50 HEX SET Z/P 8.8 | 4 |
| 14 | C021-0127 | M12 FORM C WASHER Z/P | 8 |

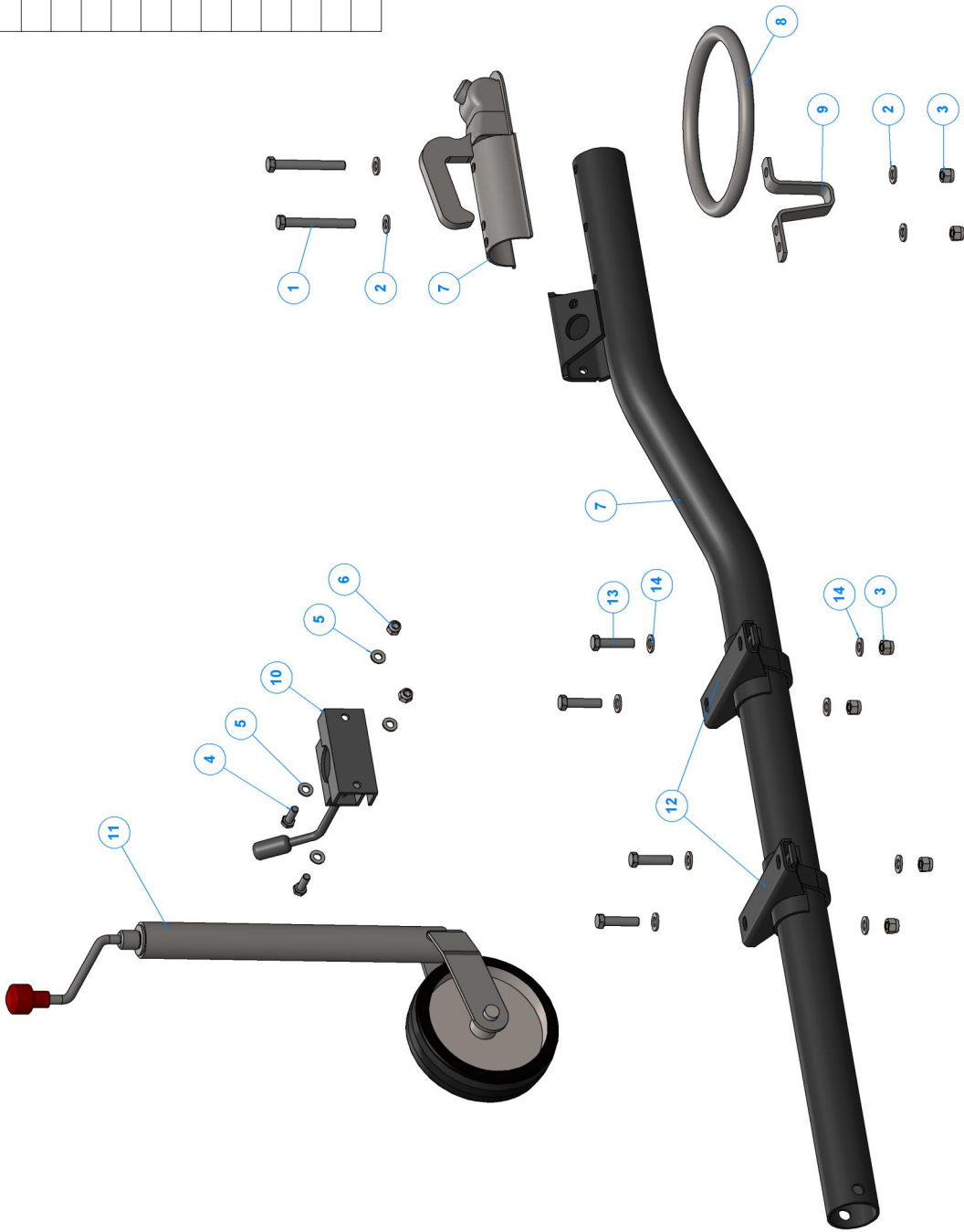

| ITEM NO. | PART NUMBER | DESCRIPTION | QTY. |
|----------|-------------|----------------------------|------|
| 1 | C021-0107 | M12 FORM A WASHER ZIP | 2 |
| 2 | C031-0165 | M12 TYPE P NYLOC NUT ZIP | 2 |
| 3 | C021-0133 | M24 FORM C WASHER ZIP | 1 |
| 4 | C002-1018 | M16 x 70 HEX SET ZIP 8.8 | 1 |
| 5 | C021-0129 | M16 FORM C WASHER ZIP | 1 |
| 6 | C031-0167 | M16 TYPE P NYLOC NUT ZIP | 1 |
| 7 | C002-1016 | M16 x 60 HEX SET ZIP 8.8 | 1 |
| 8 | C079-0101 | M10 x 35 Roll Pin Steel | 1 |
| 9 | C046-0811 | Bolt M12/35 Cup Square Bzp | 2 |
| 10 | 4109M | M16 Clamp Nut | 1 |
| 11 | P0001147 | Discharge Tube Assy | 1 |
| 12 | P0001411 | Bucket Discharge Tube Assy | 1 |
| 13 | 2837M | Clamp Discharge | 1 |
| 14 | 1649M | Tommy Bar | 1 |

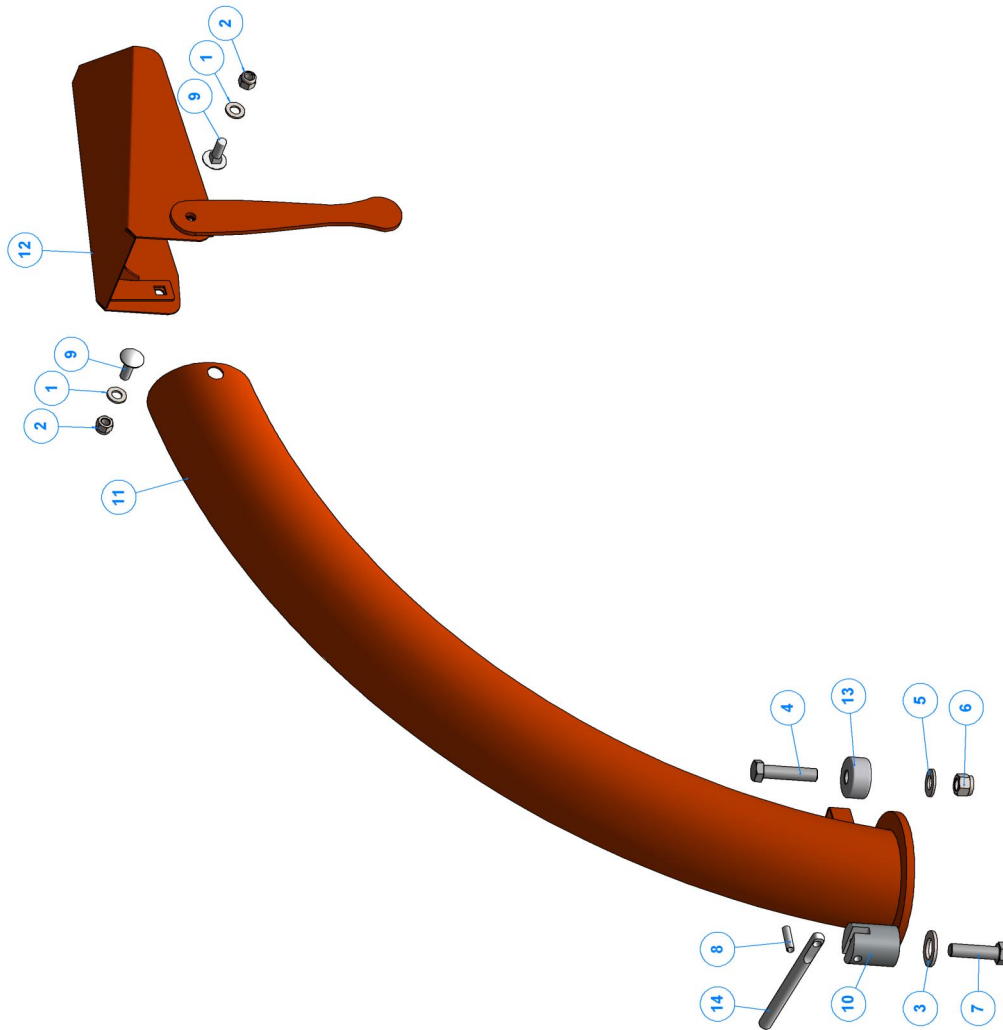

| ITEM NO. | PART NUMBER | DESCRIPTION | QTY. |
|----------|-------------|--|------|
| 1 | C002-0614 | M8 x 50 HEX SET Z/P 8.8 | 4 |
| 2 | C021-0125 | M8 FORM C WASHER Z/P | 8 |
| 3 | C031-0163 | M8 TYPE P NYLOC NUT Z/P | 4 |
| 4 | C021-0105 | M8 FORM A WASHER Z/P | 4 |
| 5 | C002-0607 | M8 x 20 HEX SET Z/P 8.8 | 4 |
| 6 | C005-0303 | M5 x 12 SKT CAP SET Z/P 12.9 | 4 |
| 7 | 19504 | Engine Briggs & Stratton 18Hp V-Twin (Vanguard Twin-Cylinder) Electric Start | 1 |
| 8 | 19505 | Muffler Kit | 1 |
| 9 | PU1609 | Pulley 125 - 3 SPA | 1 |
| 10 | 0061 | Engine Shaft Key | 1 |
| 11 | C124-A122 | Wedge Belt 1232 SPA | 3 |
| 12 | 2012-25 | Taper Lock 2012 1" Ø | 1 |

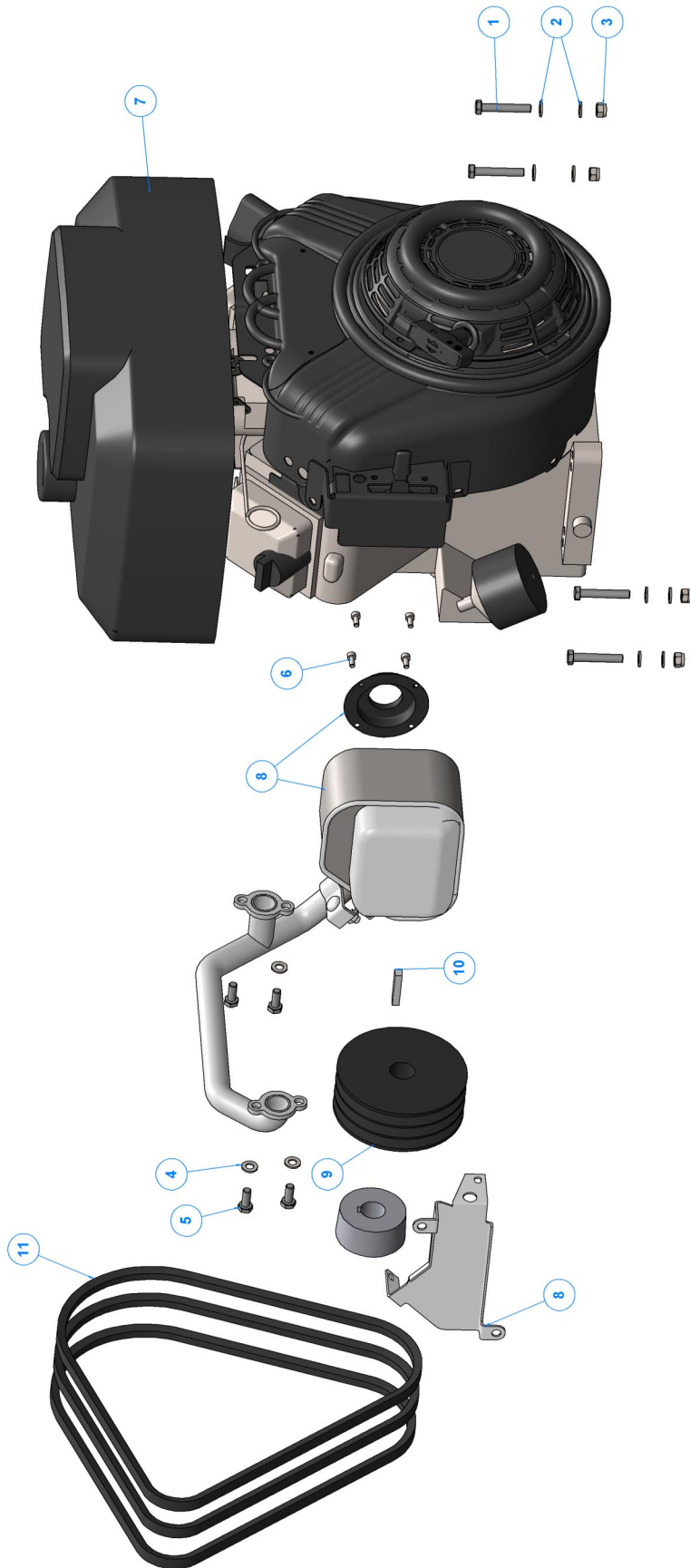

| ITEM NO. | PART NUMBER | DESCRIPTION | QTY. |
|----------|-------------|---|------|
| 1 | C013-0405 | M6 x 16 PAN POZI ZIP | 7 |
| 2 | C021-0123 | M6 FORM C WASHER ZIP | 27 |
| 3 | C031-0121 | M6 TYPE T NYLOC NUT ZIP | 25 |
| 4 | C011-0607 | M8 x 20 SKT BUTTON SET ZIP 10.9 | 3 |
| 5 | C021-0125 | M8 FORM C WASHER ZIP | 6 |
| 6 | C031-0123 | M8 TYPE T NYLOC NUT ZIP | 3 |
| 7 | C002-0407 | M6 x 20 HEX SET ZIP 8.8 | 18 |
| 8 | C021-0107 | M12 FORM A WASHER ZIP | 4 |
| 9 | C030-0125 | M12 HEX NUT - ZIP - GRADE 10 | 4 |
| 10 | C051-0107 | 19mm External Hole Ø x 12 mm ID Open Grommet | 4 |
| 11 | C021-0103 | M6 FORM A WASHER ZIP | 16 |
| 12 | C013-0203 | M4 x 12 PAN POZI ZIP | 4 |
| 13 | C021-0101 | M4 FORM A WASHER ZIP | 4 |
| 14 | C035-0102 | M4 TYPE P NYLOC NUT ZIP | 4 |
| 15 | FT691F | Funnel Feed (Inner Fabricated) | 1 |
| 16 | P0000144 | Operator's Manual Canister | 1 |
| 17 | C138-0136 | TW18/100G Tray Assembly | 1 |
| 18 | C162-0100 | ESD - Schneider XALK178F 2NC, 1NO | 2 |
| 19 | C138-0134 | Safety Curtain Rail TW18/100G | 1 |
| 20 | C138-0135 | Safety Curtain Strip | 5 |
| 21 | FT1506 | Springbolt 3-8 inch Ø | 2 |
| 22 | 19650F | Safety Curtain Clamp | 5 |

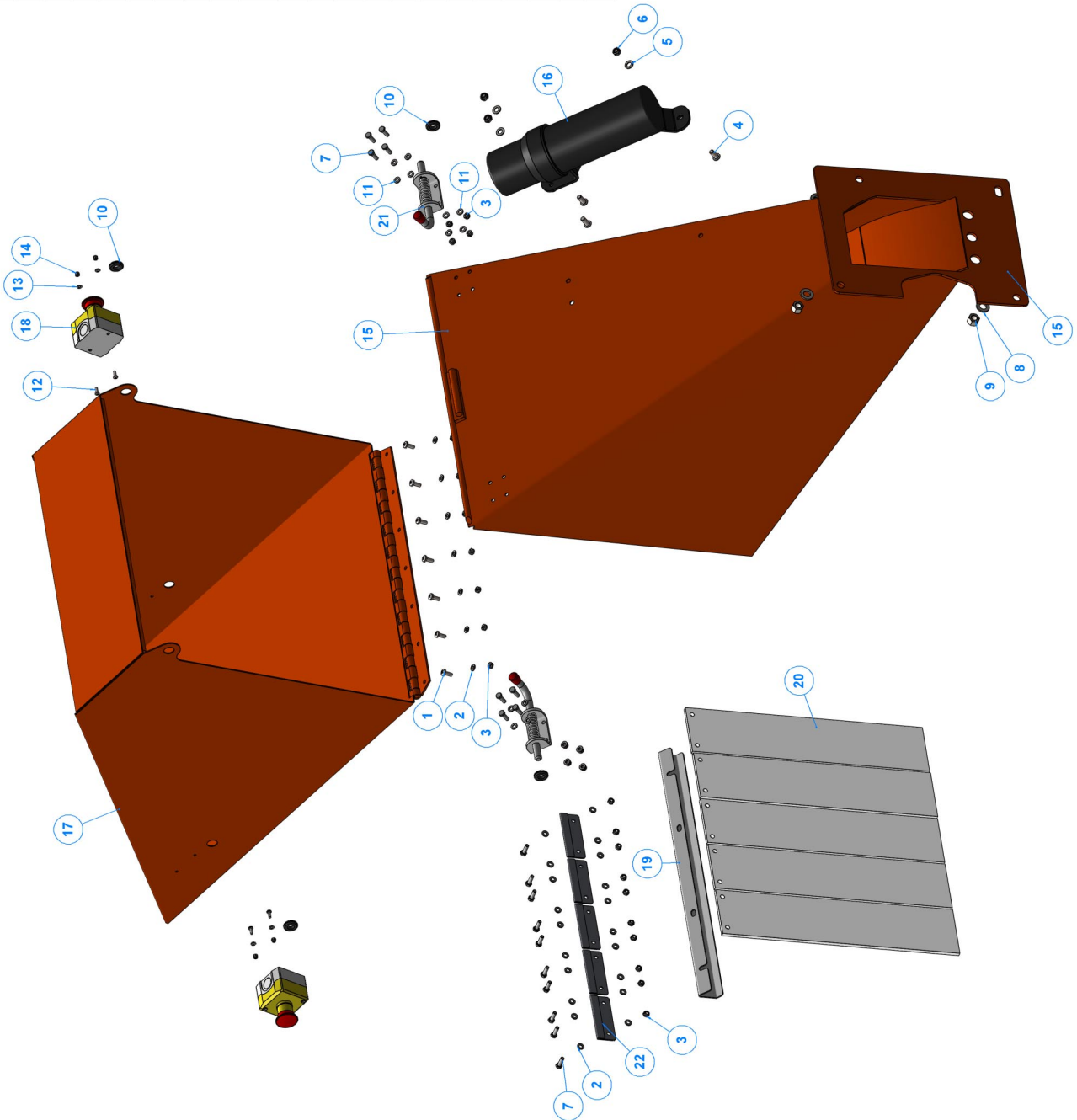

| ITEM NO. | PART NUMBER | DESCRIPTION | QTY. |
|----------|-------------|--|------|
| 1 | C021-0106 | M10 FORM A WASHER ZIP | 6 |
| 2 | C005-0710 | M10 x 30 SKT CAP SET ZIP 12.9 | 6 |
| 3 | 0065 | M8 x 20 mm Blade Bolt | 10 |
| 4 | C128-0105 | Bearing 6205 2Rs C3 | 2 |
| 5 | C002-0807 | M12 x 20 HEX SET ZIP 8.8 | 1 |
| 6 | C128-0106 | 6208 C3 | 1 |
| 7 | 1083M | Rotor | 1 |
| 8 | 0071MH | BLADE 7 INCH (GRAVITY FEED) | 2 |
| 9 | 1571 | Fan Section | 2 |
| 10 | 18947M | Rotor Shaft | 1 |
| 11 | 0883M | 0883M | 1 |
| 12 | 0884M | Front Bearing Housing | 1 |
| 13 | 0415M | Heavy Washer M12 | 1 |
| 14 | 4063M | Bearing Housing Rear (Round) 6208 2RS C3 | 1 |
| 15 | PU1351 | Pulley 200 - 3 SPA | 1 |
| 16 | C122-0717 | T'Lock Bush 2517-38 | 1 |
| 17 | 0959 | Plastic Cap | 1 |
| 18 | 18961 | 10 x 8 x 80mm Keyway | 1 |
| 19 | 1611M | Nose Shaft | 1 |
| 20 | 0796P | 20 Thou Shim | 1 |

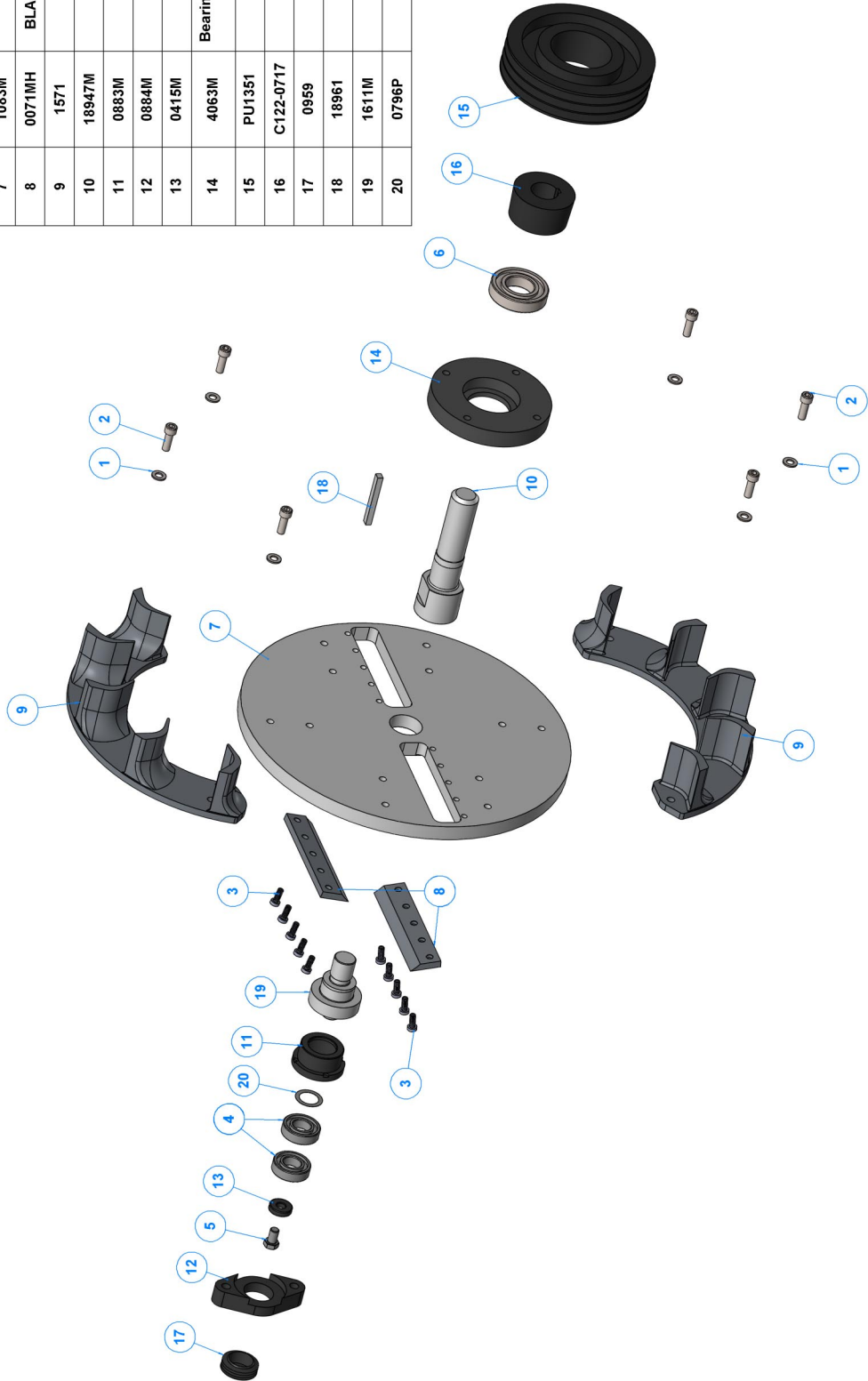

| ITEM NO. | PART NUMBER | DESCRIPTION | QTY. |
|----------|-------------|-------------------------------|------|
| 1 | C013-0307 | M5 x 20 PAN POZI ZIP | 2 |
| 2 | C021-0102 | M5 FORM A WASHER ZIP | 2 |
| 3 | C031-0120 | M5 TYPE T NYLOC NUT ZIP | 2 |
| 4 | C005-0605 | M8 x 16 SKT CAP SET ZIP 12.9 | 3 |
| 5 | C021-0107 | M12 FORM A WASHER ZIP | 11 |
| 6 | C031-0125 | M12 TYPE T NYLOC NUT ZIP | 11 |
| 7 | C021-0101 | M4 FORM A WASHER ZIP | 2 |
| 8 | C013-0209 | M4 x 30 PAN POZI ZIP | 2 |
| 9 | 19758F | Rotor Housing Welded Assembly | 1 |
| 10 | 1096F | FRONT PLATE ROTOR HOUSING | 1 |
| 11 | 0105MH | Anvil (Gravity Feed) | 1 |
| 12 | 18923 | REFLECTOR AMBER ROUND SIDE | 2 |
| 13 | C141-0118 | Access Hatch Assembly | 1 |
| 14 | EL1348 | Switch Limit (Metal Plunger) | 1 |
| 15 | C021-0127 | M12 FORM C WASHER ZIP | 1 |
| 16 | C002-0807 | M12 x 20 HEX SET ZIP 8.8 | 1 |
| 17 | C021-0125 | M8 FORM C WASHER ZIP | 2 |
| 18 | C002-0607 | M8 x 20 HEX SET ZIP 8.8 | 2 |
| 19 | 19486F | Belt Guard Assembly | 1 |
| 20 | 0361 | Thumbscrew | 1 |

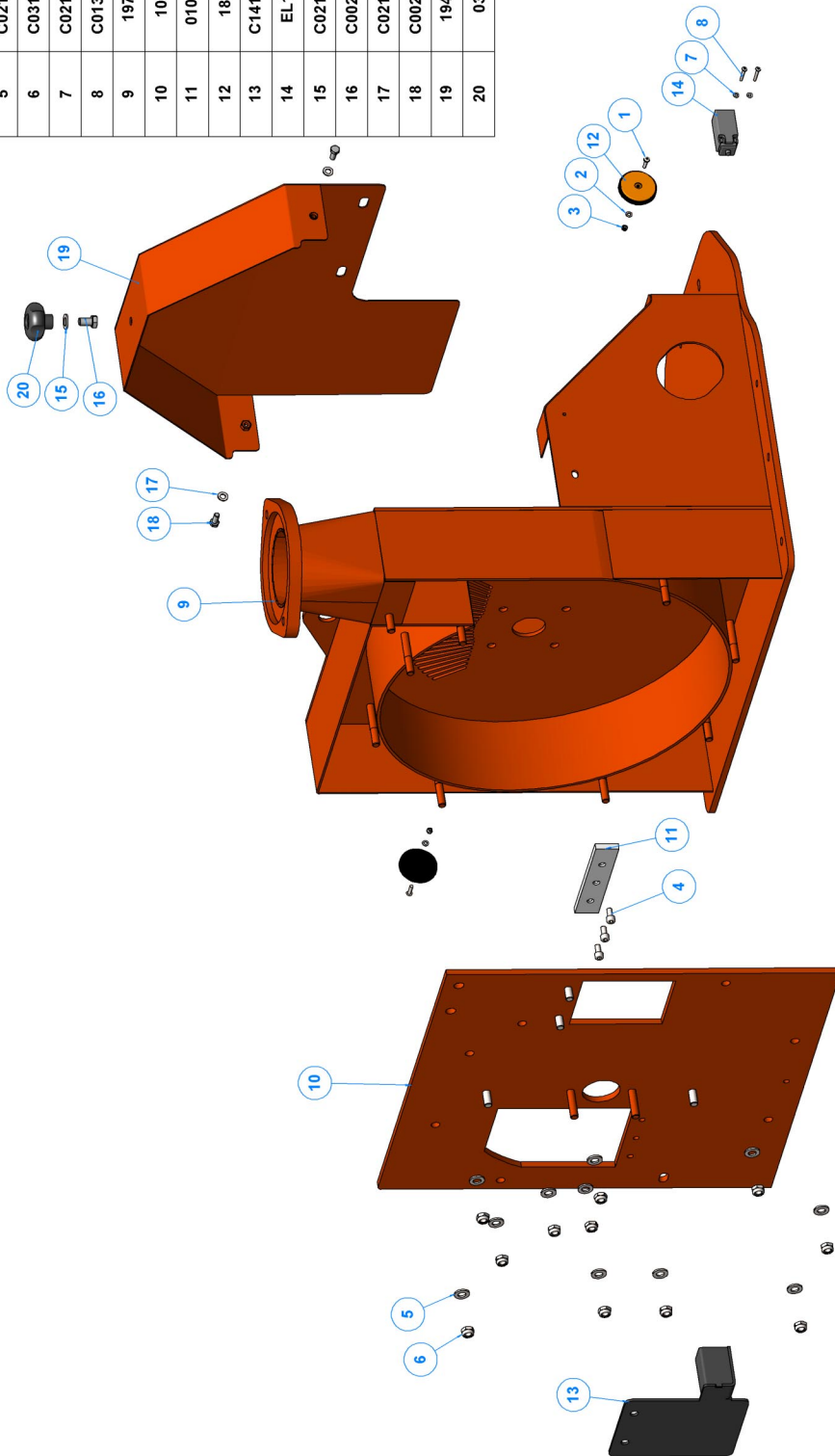

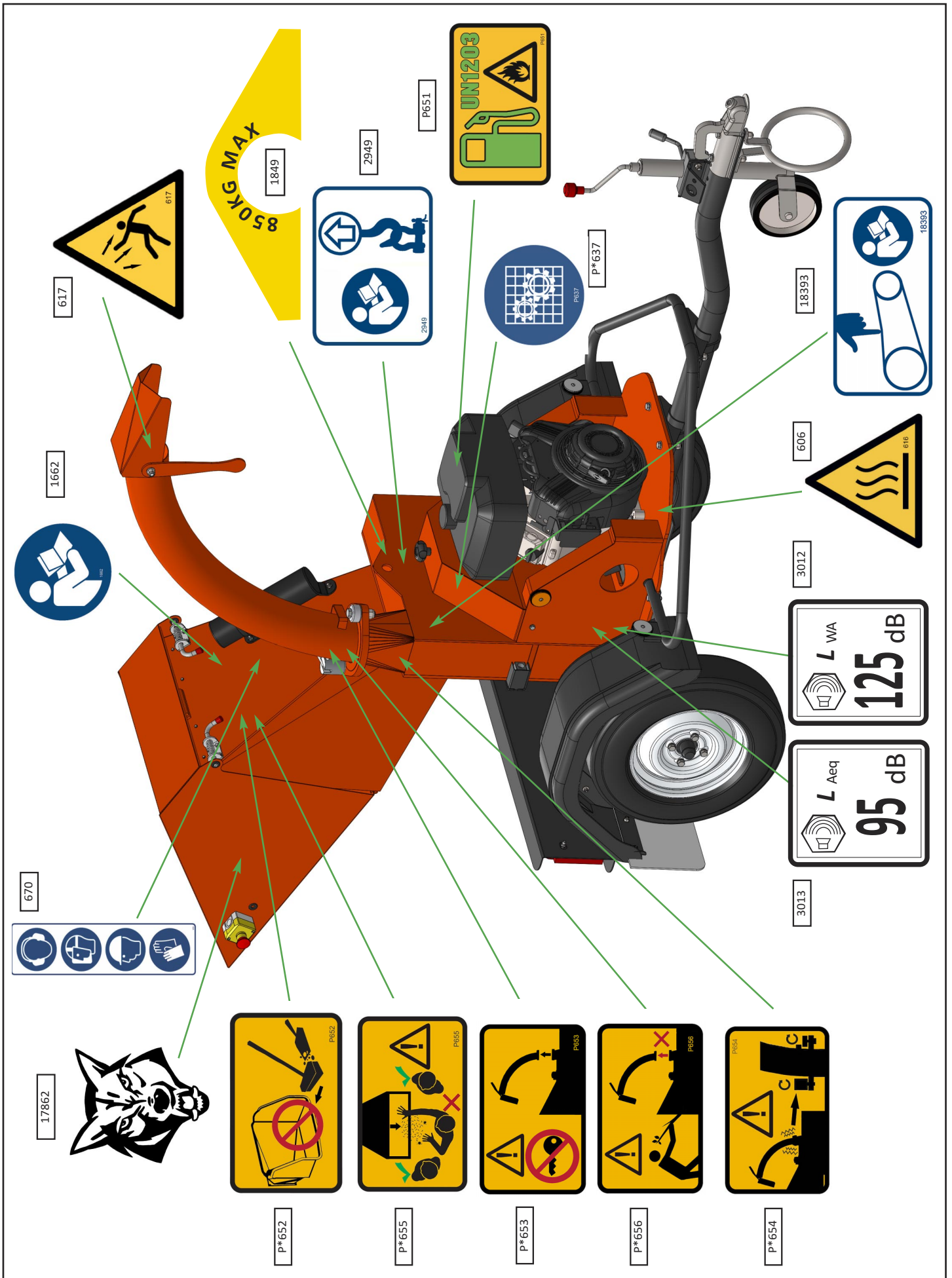

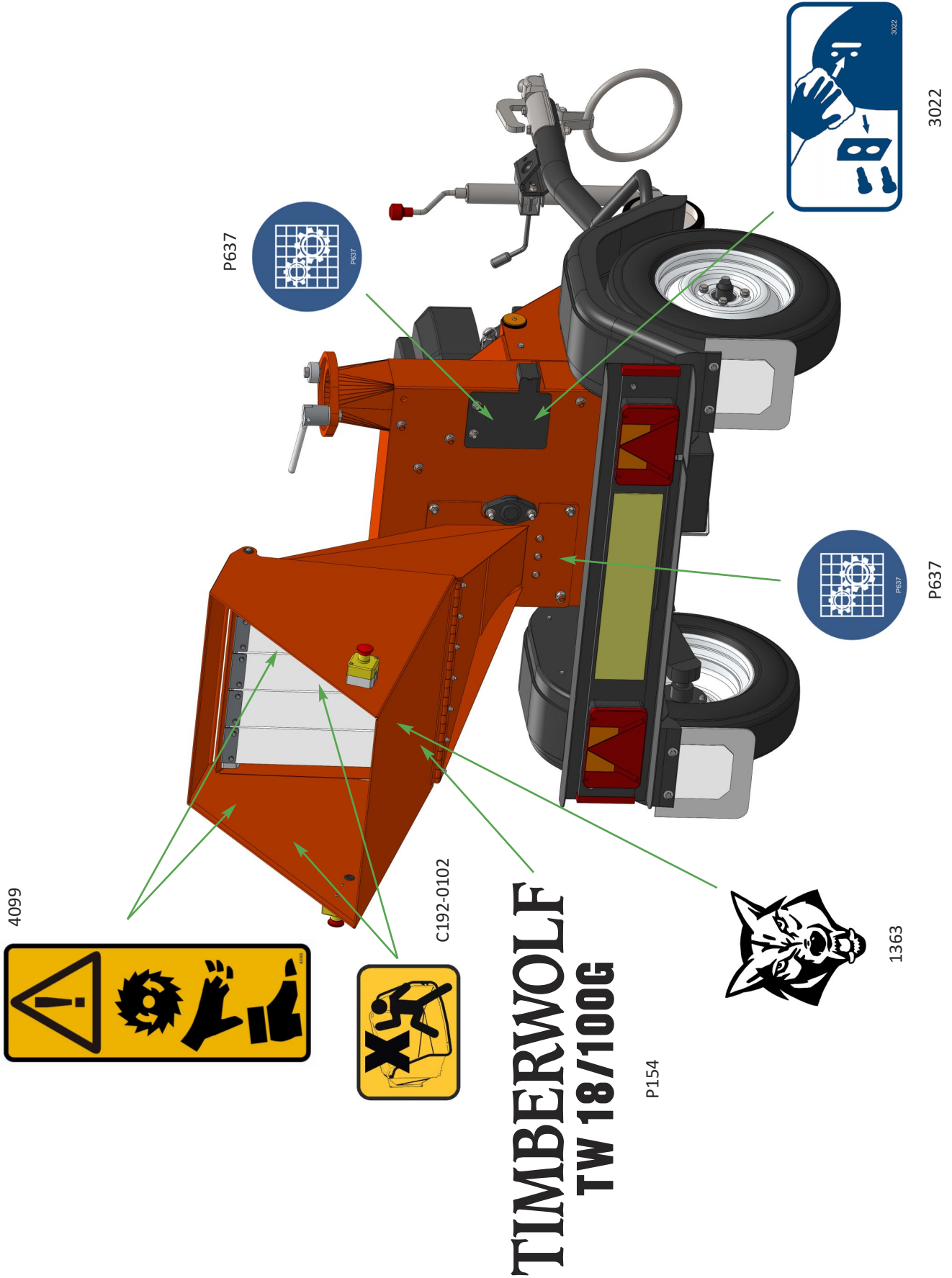



Timberwolf Ltd Wood Chippers & Shredders

Tomo Industrial Estate, Stowmarket, Suffolk IP14 5AY, United Kingdom

T: +44 1449 765800 E: info@timberwolf-uk.com W: timberwolf-uk.com



timberwolf-uk.com